

ZPL IITM

PROGRAMMING GUIDE

**46469L
REV. 1**



Proprietary Statement

This manual contains proprietary information of Zebra Technologies Corporation. It is intended solely for the information and use of parties operating and maintaining the equipment described herein. Such proprietary information may not be used, reproduced, or disclosed to any other parties for any other purpose without the expressed written permission of Zebra Technologies Corporation.

Product Improvements

Continuous improvement of products is a policy of Zebra Technologies Corporation. All specifications and signs are subject to change without notice.

FCC Compliance Statement

Note: This equipment has been tested and found to comply with the limits for a Class A digital Device, pursuant to Part 15 of the FCC Rules. These limits are designed to provide reasonable protection against harmful interference when the equipment is operated in a commercial environment. This equipment generates, uses and can radiate radio frequency energy and, if not installed and used in accordance with the instructions manual, may cause harmful interference to radio communications. Operation of this equipment in a residential area is likely to cause harmful interference in which case the user will be required to correct the interference at his own expense.

In order to insure compliance, this printer must be used with a Shielded Power Cord and Shielded Communication Cables.

"The user is cautioned that any changes or modifications not expressly approved by Zebra Technologies Corporation could void the user's authority to operate the equipment."

Canadian DOC Compliance Statement

This digital apparatus does not exceed the Class A limits for radio noise emissions from digital apparatus as set out in the radio interference regulations of the Canadian Department of Communications.

Liability Disclaimer

Zebra Technologies Corporation takes steps to assure that its published Engineering specifications and Manuals are correct; however, errors do occur. Zebra Technologies Corporation has been advised of the possibility of such damages. Because some states do not allow the exclusion or limitation of liability for consequential or incidental damages, the above limitation may not apply to you.

Copyrights

The copyrights in this manual and the label printer described therein are owned by Zebra Technologies Corporation. All rights are reserved. Unauthorized reproduction of this manual or the software in the label printer may result in imprisonment of up to one year and fines of up to \$10,000 (17 U.S.C.506). Copyright violators may be subject to civil liability.

ZPL[®] is a registered trademark of Zebra Technologies Corporation

ZPL II[™] is a trademark of Zebra Technologies Corporation

Zebra STRIPE[®] is a registered trademark of Zebra Technologies Corporation

IBM is a registered trademark of IBM Corporation

© 1994 Zebra Technologies Corporation

Table of Contents

Introduction To ZPL II™

Scope of This Manual	1-1
Zebra Programming Language II (ZPL II)	1-1
Why ZPL II and How it Differs from Standard ZPL	1-1
Working with Examples	1-2
Setting Factory Default Parameters	1-3

ZPL II Basics

More Information About ZPL II.	2-1
Format Instructions	2-3
Control Instructions	2-4
Prefix Rules and Syntax	2-4
Label Format Instructions	2-6
Format Bracket Instructions	2-6
Example for Using ^XA and ^XZ Instructions	2-6
Label Definition Instructions	2-7
Using the ^LS Instruction	2-10
Format Rotation Instructions.	2-12
Field Definition Instructions	2-15
Understanding ^FO and ^FT Instructions	2-17
Example 1 for Using ^FO, ^FD, and ^FS	2-19
Example 2 for Using ^FO, ^FD, and ^FS	2-19
Embedding HEX Codes in Field Data Statements	2-20
Field Block.	2-21
Introduction to Device Names.	2-24
Introduction to ZPL II Object Names and Extensions	2-24
Using Device and Object Names with ZPL II Instructions.	2-25
Defining and Using the AUTOEXEC.ZPL Function.	2-26
Using Battery Powered Font Cards	2-26

Printer Configuration

Print Mode	3-3
Media Tracking	3-4
Media Type	3-5
Media Darkness	3-6
Label Top Position	3-7
Set Media Sensors	3-8
Mode Protection	3-10
Reprint After Error	3-11
Configuration Update	3-12
Set ZPL	3-13
Setting Up Customized Configuration Formats	3-14

Text for Labels

Zebra Fonts	4-1
Understanding Bit-Mapped Font Magnification Factors	4-2
International Character Sets	4-3
Graphic Symbol Instruction	4-4
Font Selection	4-5
Change Alphanumeric Default Font Instruction	4-5
Alphanumeric Font Instructions	4-6
Example for Using ^Ax Instruction	4-7
Default Fonts and Font Matrices	4-8
Proportional Spacing	4-10
Bit-Map Font Size	4-11
Scalable Font Size	4-12
Differences Between Download Scalable Fonts and Bitmap Fonts	4-13
Cache On	4-14
Notes on Print Cache Performance	4-16
Download Bitmap Font	4-17
Downloadable Scalable Fonts	4-19
Download Scalable Font	4-20
Font Identifier	4-21

Bar Codes

Basic Format for Bar Codes	5-1
Bar Code Field Instructions	5-2
Typical Instructions for Printing a Bar Code	5-4
Field Default Instructions	5-6
Bar Code Field Default Instruction	5-6
Numeric-Only Bar Codes	5-8
Code 11 Bar Code	5-8
Interleaved 2 of 5 Bar Code	5-10
Industrial 2 of 5	5-12
Standard 2 of 5	5-14
Codabar Bar Code	5-16
MSI Bar Code	5-18
Plessey Bar Code	5-20
POSTNET Bar Code	5-22
Retail Labeling Bar Codes	5-24
EAN-8 Bar Code	5-24
UPC-E Bar Code	5-26
EAN-13 Bar Code	5-28
UPC/EAN Extensions	5-30
UPC-A Bar Code	5-34
Alphanumeric Bar Codes	5-36
Code 39 Bar Code	5-36
Code 93 Bar Code	5-38
Code 128 Bar Code (Subsets A, B, and C)	5-40
Special Conditions if UCC Case Mode is Selected	5-43
Code 128 Subsets	5-43
Example of Code 128 - Subset B	5-44
Example of Code 128 - Subsets A and C	5-45
LOGMARS Bar Code	5-46
Full ASCII Mode for Code 39	5-48
Full ASCII Mode for Code 93	5-50
Two-Dimensional Bar Codes	5-52
Code 49 Bar Code	5-52
Code 49 Field Data Character Set	5-55
Advantages of Using the Code 49 Automatic Mode	5-55
PDF417 Bar Code	5-56

Special considerations for the ^BY instruction when using PDF417.....	5-59
Special considerations for the ^FD character set when using PDF417.....	5-59
Bar Code Validation.....	5-60

Graphic Instructions

Boxes and Lines	6-2
Example for Drawing a Box	6-3
Example for Drawing a Vertical Line.....	6-3
Example for Drawing a Horizontal Line.....	6-3
Working with Hex Graphic Images	6-4
Downloading a Graphic Image	6-4
Alternative Data Compression Scheme for ~DG and ~DB Instructions.....	6-7
Repeat Values.....	6-8
Reducing Download Time of Graphic Images.....	6-9
Recalling a Hexadecimal Graphic Image.....	6-10
Image Move	6-11
Working with Label Formats as Graphics	6-12
Saving Label Formats in Memory as Graphic Images	6-12
Recalling Label Formats from Memory.....	6-14
Transferring Objects Between Storage Devices	6-15
Transfer Object	6-15
Transferring Multiple Objects	6-16
Deleting Graphics from Memory	6-17
Deleting all Graphic Images from DRAM	6-18

Advanced Techniques

Nonprinting Comments	7-1
Special Effects for Print Fields.....	7-2
Reverse Printing a Field	7-2
Reverse Printing a Label.....	7-3
Printing a Mirror Image	7-4
Serialized Data	7-5
Using Leading Zeros.....	7-5

Variable Data	7-8
Map Clear	7-8
Variable Field Data	7-9
Stored Formats	7-10
Initialize/Erase Stored Formats	7-10
Download Format Instruction	7-11
Field Number Instruction	7-13
Field Allocate	7-13
Recall Stored Format Instruction	7-14
Local Directory List	7-15
More Examples of Using Stored Format	7-16
Control Instructions	7-17
Test and Setup Instructions	7-17
Calibration and Media Feed Instructions	7-19
Cancel/Clear Instructions	7-20
Printer Control Instructions	7-21
Explanations of Values for the ^PQ 'o' Parameter	7-23
Examples of the ^PQ Instruction	7-23
Limitations of Higher Print Speeds	7-25
Change Backfeed Sequence	7-26
Set Dots/Millimeter	7-28
Display Control Instructions	7-29
Changing Delimiters and Instruction Prefixes	7-30
Changing the Format Instruction Prefix	7-30
Changing the ZPL Delimiter Character	7-31
Changing the Command Instruction Prefix	7-31
Communication Diagnostics Instructions	7-32
Host Status Instructions	7-33
Host Directory List	7-33
Host Identification	7-35
Host Verification	7-35
Print Configuration Label	7-36
Start Print	7-36
Networking	7-38
Assigning a Printer ID	7-38
Connecting Printers into the Network	7-39
Set All Printers Transparent	7-39
Set Currently Connected Printer Transparent	7-39

How to Set Up a Network	7-40
Network Use	7-41

Programming Exercises

Introduction	8-1
Exercise #1 - Creating a Simple Label	8-3
Exercise #2 - Changing Text and Bar Code Parameters	8-6
Exercise # 3 - Changing Default Text Parameters, Using International Character Sets, and Using Graphic Symbols	8-9
Exercise # 4 - Non-Printing Field and Field Rotation	8-12
Exercise # 5- Line and Box Graphics,	8-15
Reverse Printing Fields	8-15
Exercise # 6 - Saving Label Formats as Graphic Images	8-19
Exercise # 7 - Downloading and Printing Graphic Images	8-22
Exercise # 8 - Deleting Graphic Images	8-27
Exercise # 9 - Printing Quantities of Labels, Printing Entire Label in Inverted Orientation, Setting the Print Rate and Suppressing Backfeed	8-30
Exercise # 10 - Slew Instruction, Form Feed Instruction and Printing Entire Formats in Reverse	8-33
Exercise # 11 - Using Serialized Fields	8-37
Exercise # 12 - Stored Formats	8-40
Exercise # 13 - Erasing Stored Formats	8-44
Exercise # 14 - Using Variable Data Fields	8-47

Appendix A - ASCII Code Chart

Appendix B - Mod 10 Check Digit

Appendix C - Mod 43 Check Digit

Appendix D - Host Status Return

Appendix E - Memory Status Return

Appendix F - Code Page 850 Chart

Appendix G - Error Detection Protocol

Introduction	G-1
What is a Protocol	G-1
How Protocol Works	G-1
Request Packet Formats (from the Host computer)	G-2
Response From the Zebra Printer	G-4
Zebra Packet Response	G-4
Disguising Control Code Characters.	G-6
Rules for Transactions	G-7
Error Detection Protocol Application.	G-7
Activating the Protocol	G-7
Setting Up Communications	G-7
Setting the Printer ID Number	G-8
Error Conditions and System Faults	G-8
Restarting a Transmission	G-8
CRC Error Conditions and Responses	G-8
Time-Out Error Conditions and Responses.	G-9
How the Zebra Printer Processes a Request Packet	G-10
How the Zebra Printer Responds to Host Status	G-11

THIS PAGE INTENTIONALLY LEFT BLANK

Scope of This Manual

This manual is a guide to the functions and features of the Zebra Programming Language II (ZPL II™).

Zebra Programming Language II (ZPL II)

Zebra Programming Language II (ZPL II) is a high-level label definition and printer control language. Labels may be defined in ZPL II Language and generated by a host computer system. A commercial label preparation system or a software package which automatically generates ZPL II Code may also be used. For information about label preparation systems, consult your distributor, systems integrator, or computer software vendor.

Why ZPL II and How it Differs from Standard ZPL

The primary reason for the development of ZPL II was to substantially reduce the time between when a printer begins receiving label format data and when the first label begins to print. This was accomplished primarily by changing the way ZPL scripts are written.

THEREFORE ZPL II SCRIPTS ARE NOT 100% COMPATIBLE WITH STANDARD ZPL SCRIPTS

In reality, the differences between ZPL II and Standard ZPL scripts is minor. Most existing Standard ZPL scripts can be easily modified to take advantage of ZPL II. You can also write ZPL II scripts that are compatible with Standard ZPL printers.

There are two major changes between ZPL II and Standard ZPL.

- 1) With ZPL II, **ALL** data fields are formatted as received. This is the major change from Standard ZPL. In Standard ZPL, the data fields are not processed until after the **^XZ (End of Label Format) instruction is received.**

- 2) A new instruction called **^SP** (Start Print) has been added.
This instruction is explained in detail on Page 7-36

In order to take advantage of ZPL II, it is **MANDATORY** that if the following ZPL II instructions are used in a label format, they **MUST COME BEFORE THE FIRST DATA FIELD**.

^JM, ^LH, ^LL, ^LR, ^LS, ^PM, ^PO, ^PR, and ^PF

NOTE: If these instructions are used in a label format and are not placed before the first data field, the label will not print correctly.

Working with Examples

Examples are used throughout this manual to assist and instruct both new and more experienced users. Each example has two parts; the actual instructions sent to the printer and the results (usually in the form of a printed label) of those instructions.

It is strongly suggested that new users go through each of the examples, comparing their results with the one shown. Experienced users may only need to read over the examples, making sure they understand how the results were obtained.

Most of the examples are “stand-alone” and can be completed on an individual basis. However, some examples assume that a previous example has already been completed. For instance, an example may delete a previously saved graphic image.

Before working with the examples, be sure the supplies (ribbon and media) have been loaded and that the printer has been properly adjusted for the media (labels). If unfamiliar with these procedures, refer to the User’s Manual or Operator Guide for assistance.

The examples shown in this guide assume a media size of at least 80mm wide and 60mm long. Media of different sizes can be used, however parameters affecting size or location of printed data may need to be modified.

Continuous media can also be used for these examples. Be sure to set the label length using the **^LL** instruction. We recommend using a label length of 480 dot rows by adding the instruction **^LL480^FS** after the **^XA** instruction line. Both of these instructions are covered in detail in Chapter 2, ZPL II Basics.

These examples are designed for a Zebra printer controlled by “stand-alone” (i.e. not part of a network) IBM[®] compatible personal computers. The ZPL II Language uses only printable ASCII characters. Although a Zebra printer may be controlled by mainframes, minicomputers or the ZEBRA-MATE™ data entry terminal, we’ve chosen the personal computer as a programming source because of its relative familiarity among users.

Any word processor or text editor capable of creating ASCII-only files (files without formatting codes and other extraneous information) can be used to create the programs in these examples. For instance, if you are using WordStar™ you would open a NON-DOCUMENT file.

Almost all of the examples are made up of a series of lines. When you finish typing a line, press the **RETURN** or **ENTER** key. Then type in the next line. Continue this process for all of the lines in the example.

Setting Factory Default Parameters

Factory Default Parameters should be used when working with the examples. The procedure for setting factory defaults depends on the particular printer.

To insure that Factory Default Parameters are in effect, turn the printer Power OFF for 10 to 15 seconds. Then, while pressing the **FEED** and **PAUSE** keys, turn the printer Power ON. Soon, all of the indicators will go OFF except for the POWER and PAUSE. Press the PAUSE key. Only the POWER indicator will remain ON.

Preform a Media Calibration (and Set Head Resistance if required) as described in User’s Manual or Operator Guide. The Factory Defaults will now be stored in the printer until changed by one or more ZPL II instructions.

WARNING: The Factory Default for the Darkness (“burn temperature”) setting is set to a low “safe” value at the factory. This value may have to be changed for proper printing. Refer to either the User’s Manual, Operator Guide or Chapter 3 of these instructions for information on how to change this value.

THIS PAGE INTENTIONALLY LEFT BLANK

ZPL II is Zebra Technologies trademark for its *Zebra Programming Language II*. ZPL II instructions sent to a Zebra printer give you the ability to create a wide variety of labels from the simple to the very complex. The labels can include any combination of text, bar codes, and graphics.

More Information About ZPL II

ZPL II Language contains a variety of font styles and bar codes. Various ZPL II instructions let you position print fields anywhere on a label in a horizontal orientation or rotated 90, 180 or 270 degrees clockwise. Graphic images can be read and interpreted provided they are in a “hexadecimal format.” Therefore, if you can convert a scanned or computer-generated image (i.e. image created using a draw or paint software program) into hexadecimal format, you can print it on a label.

ZPL II instructions consist of a prefix character, a two-character mnemonic code and, where applicable, a parameter string. The entire language is programmable in printable ASCII characters, which allows easy passage of formats and data through computer networks and protocol converters. ZPL II instructions do not use escape sequences or control codes. A few instructions do have ASCII control code equivalents, which are noted as they apply.

Zebra Programming Language II is both powerful and flexible, providing all of the following features:

- Compatibility with PCs, minicomputers, mainframe computers and networks.
- Serialized label fields, with user-selected starting value and increment/decrement value.
- Programmable label replicate count, batch quantity control, and printer pauses that enable batching of labels into usable groups
- Simple line graphics to eliminate label pre-printing.
- Scalable fonts. (Smooth Fonts in the Zebra STRIPE S-300 printer.)

- Bit-image graphics, with library function capability (to store more than one graphic and recall as needed), for free-form graphic designs.

You can create and use ZPL II programs one at a time from any word processor capable of generating an ASCII text file. You can integrate your Zebra printer into your operations by using database programs and other languages to generate ZPL II programs. The ZPL II program is then sent to the Zebra printer through an appropriate interface (combination of proper cabling, printer configuration, and software settings). The examples in this guide use printable ASCII characters in all instructions, unless otherwise noted.

Note: ZPL II instructions can be entered in either upper case characters, lower case characters or a combination of both.

There are two types of ZPL II instructions: Format Instructions and Control Instructions. The discussion of these instructions begins on the next page.

Format Instructions

Format instructions are the blueprint of a label. These instructions define label length, field origin, type of field, field data and other information. Format instructions are always preceded by the caret (^) character. All format instructions are processed in the order received.

Most format instructions are, for the most part, “order-independent.” For example, instructions to print text at the bottom of a label can come before the instruction to print a bar code at the top of the same label.

However, due to the processing method used, some format instructions must be placed before others within the label format. These are **^LH (Label Home)**, **^LL (Label Length)**, **^LR (Label Reverse)**, **^LS (Label Shift)**, **^JM (Set Dots/Millimeter)**, **^PM (Mirror Image)**, **^PO (Print Orientation)**, **^PR (Print Rate)** and **^PF (Slew Dot Rows)**. These will be discussed in detail in this and other sections of this manual. (*Note that this is different from standard ZPL.*)

Multiple label formats are acted on in the order they are received by the printer.

Format instructions fall into several categories:

- Format bracket instructions
- Label definition instructions
- Field definition instructions
- Field default instructions
- Format default instructions
- Format rotation instructions
- Printer control instructions
- Alphanumeric field instructions
- Bar code field instructions
- Graphic image instructions

Control Instructions

Control instructions are preceded by a tilde (~) character. In most cases, they cause the printer to take a specific action immediately, such as clearing the memory or feeding a blank label. Control instructions may interrupt and preempt any format instructions waiting in the buffer.

Prefix Rules and Syntax

Format instructions use the caret (^) prefix.

An “RS” (HEX 1E) can be substituted for the (^).

Control instructions use the tilde (~) prefix.

A “DLE” (HEX 10) can be substituted for the (~).

Note: Both Format and Control prefixes can be changed via ZPL II.

In ZPL II instructions, the caret (^) is treated as an ordinary ASCII character like any other character you would type in from the keyboard.

In this manual, when you see the caret (^) character, it indicates that you are to type the caret (^) character.

The caret (^) is a single printable ASCII character having the code 5E HEX or 94 decimal. Similarly, the tilde (~) is a single printable ASCII character having the code 7E HEX or 126 decimal.

A few ZPL II instructions can be sent to the printer as either a Format instruction or a Control instruction. The action performed by the printer will be the same in either case. These instructions must be preceded by the appropriate prefix (i.e a ^ or a ~) for the context in which they are used.

Many ZPL II instructions have parameter strings associated with them. Changing the value of one or more of these parameters affects the outcome of the printed label.

If the default value for an instruction parameter suits your application, you need not specify that parameter. However, parameters are “position-specific.” If you want to change just the third parameter, for example, you must indicate that it is the third parameter that you want to change. To do so, use a comma, the ZPL II delimiter character, to mark each parameter’s place (i.e. **^AA,,60**).

The remainder of this programming guide defines all of the ZPL II Format and Control instructions. Examples are included as needed to give a better understanding of how an instruction is used. At the back of this Programming Guide is an Appendix and a ZPL II Reference Guide. In the Appendix is an ASCII Code Chart, information on calculating check digits, and other useful information.

Some instructions include the following abbreviation:
{I.V.P. = } (this signifies the Initial Value at Power-up *regardless* of the value when printer was turned off).

IF YOU PLAN ON DOING THE EXAMPLES, BE SURE TO CHANGE BACK TO THE FACTORY DEFAULTS BEFORE STARTING.

Label Format Instructions

There are several instructions used to determine where information (text, bar codes, graphics) will actually be printed on a label.

^XA, ^XZ

Format Bracket Instructions

Format Bracket instructions define the beginning and end of the format instructions for each label. The format instructions that are entered between these brackets determine how the actual printed label will look.

The **^XA** instruction is the beginning (opening) bracket. It indicates the start of a new label format. This instruction can also be issued as a single ASCII control character **STX** (Control-B, Hex 02).

The **^XZ** instruction is the ending (closing) bracket. It indicates the end of a label format. When this instruction is received, a label will be printed. This instruction can also be issued as a single ASCII control character **ETX** (Control-C, Hex 03).

Example for Using ^XA and ^XZ Instructions

The following is a very basic example of using the **^XA** and **^XZ** instructions. Sending the data in the box on the left will produce the label shown on the right.

```
^XA^CFD
^F050,50^FDZEBRA TECHNOLOGIES^FS
^F050,75^FDVernon Hills, IL
^XZ
```

```
ZEBRA TECHNOLOGIES
Vernon Hills, IL
```

There are three Label Definition instructions. One changes the label home position, one defines the label length and one is used when using regular ZPL instructions for a Z-130 printer on another Zebra printer.

The **^LH** (Label Home) instruction sets the label home position. (Refer to Figure 2.1 as you continue reading about this instruction.)

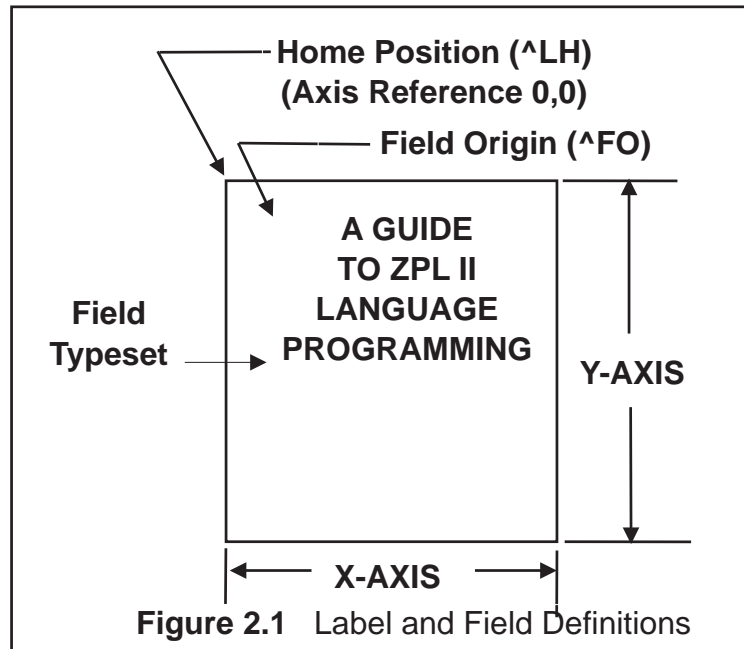

The default home position of a label is the upper-left corner (position **0,0** along the x-axis and y-axis). This is the axis reference point for labels. Any area below, and to the right of this point is available for printing. The Label Home instruction changes this reference point. For instance, when working with preprinted labels, use this instruction to move the reference point below the pre-printed area.

Note: This instruction *will only* affect fields that come after it. It is suggested that this be one of the first instructions in the label format.

The format for the **^LH** instruction is:

^LH

^LH_{x,y}

where

- ^LH** = Set Label Home
- x** = Number of dots along x-axis
{I.V.P. = 0}
Acceptable values: 0 - 9999
- y** = Number of dots along y-axis
{I.V.P. = 0}
Acceptable values: 0 - 9999

Depending on the printhead used in your printer, use one of the following when figuring the values for **x** and **y**:

- 6 dots = 1 mm (millimeter), 152 dots = 1 inch.
- 8 dots = 1 mm (millimeter), 203 dots = 1 inch.
- 11.8 dots = 1 mm (millimeter), 300 dots = 1 inch.
- 12 dots = 1 mm (millimeter), 304 dots = 1 inch.

To be compatible with existing printers, this instruction *must* come before the first **^FS** (Field Separator) instruction. Once you have issued an **^LH** command, the setting is retained until you turn off the printer or send a new **^LH** instruction to the printer.

The **^LL** (Label Length) instruction defines the length of the label. This instruction is necessary when using continuous media (i.e. media not divided into separate labels by gaps, spaces, notches, slots or holes).

To affect the current label, and/or be compatible with existing printers, this instruction *must* come before the first **^FS** instruction. Once you have issued an **^LL** command, the setting is retained until you turn off the printer or send a new **^LL** instruction to the printer.

The format for the **^LL** instruction is:

^LLx

^LL

where

^LL = Set Label Length

x = Number of dots along y-axis

Factory Default value:

1225 for Stripe

1244 for Xi printers

Note: Value must be entered or instruction is ignored.

(8 in. using 6 dot/mm printhead)

(6 in. using 8 dot/mm printhead)

(3 in. using 12 dot/mm printhead)

Acceptable values: from 1 up to some 4-digit number that does not exceed the maximum label size.

The following formula can be used for figuring the value of 'x.'

For 6 dot/mm printheads.....

Label length in inches x 152.4 (dots/inch) = value for 'x'

For 8 dot/mm printheads.....

Label length in inches x 203.2 (dots/inch) = value for 'x'

For 12 dot/mm printheads.....

Label length in inches x 304.8 (dots/inch) = value for 'x'

Note 1: Values for **x** depend on the memory size. If the entered value for **x** exceeds acceptable limits, bottom of label will be cut off. Label will also shift down from top to bottom.

Note 2: If multiple **^LL** instructions are issued in the same label format, the last **^LL** instruction will also affect the next label, unless it is prior to the first **^FS**.

The **^LS (Label Shift)** instruction allows for compatibility with Z-130 Printer formats that are set for less than full label width. It is used to Shift all field positions to the left so that the same instructions used on a Z-130 or Z-220 Printer can be used on other Zebra printers.

Using the **^LS** Instruction

To determine the value for the **^LS** instruction use the following formula. $Z-130/Z-220 \text{ values for } ^LHx + ^FOx - (\text{distance from edge of label}) = \text{printer value for } ^LSa$. If the print position is less than 0, then set **^LS** to 0.

To be compatible with existing Zebra printers, this instruction *must* come before the first **^FS** instruction. Once you have issued an **^LS** command, the setting is retained until you turn off the printer or send a new **^LS** instruction to the printer.

^LS

The format for the **^LS** instruction is:

^LSa

where

^LS = Set Label Shift
a = Shift Left Value in dots
{I.V.P. = 0}
Acceptable values: 0 to 9999 dots.

*Further explanation for using the **^LS** instruction is on the next page.*

The following is an explanation of how the **^LS** instruction works. The illustration depicts a top down view of a Z-130/Z-220 Printer and another Zebra printer sitting side by side.

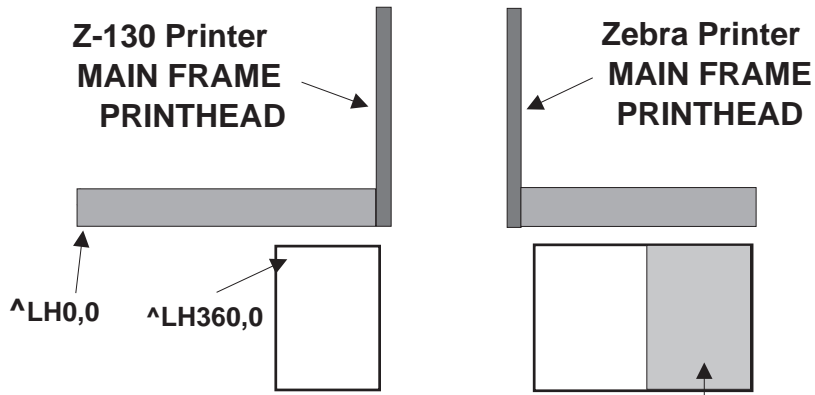

On other Zebra printers, the Z-130 instructions would print the label here. Use the **^LS instruction to position the label correctly.**

On a Z-130/Z-220 Printer, the **^LH0,0** reference is at the farthest point away from the main frame; it is just the opposite on other Zebra printers. On a Z-130/Z-220, if you are using labels that are less than the maximum width, you need to increase the **^LH** (or **^FO**) instructions to compensate for the narrower labels. However, on other Zebra printers, this is not necessary.

If a label format, with a **^LH 360,0** originally designed to print on a Z-130/Z220 was sent to some other Zebra printer, the printing would be off to the right. An **^LS 360** instruction would have to be added to the Z-130/Z-220 label format instructions to bring the label back to its proper position.

Format Rotation Instructions

There are two Format Rotation instructions. One affects only those instructions that have a rotation parameter. The other is designed to invert the entire label format 180 degrees.

The **^FW** (Field Orientation) instruction sets the default orientation for all instruction fields that have an orientation (rotation) parameter. Fields can be rotated 0, 90, 180, 270 degrees clockwise by using this instruction.

^FW

The format for the **^FW** instruction is:

^FWa

where

- ^FW** = Set Field Orientation
- a** = Rotate field
 - N = Normal **{I.V.P. = N}**
 - R = Rotated 90 degrees;
 - I = Inverted (180 degrees);
 - B = Bottom Up (270 degrees read from bottom up).

```
^XA^CFD
^FWR
^F050,40^FDZEBRA TECHNOLOGIES^FS
^F030,60^FDVernon Hills, IL
^XZ
```

```
ZEBRA TECHNOLOGIES
Vernon Hills, IL
```

Note 1: If the **^FW** instruction is entered with the 'a' parameter missing, the instruction is ignored.

Note 2: **^FW** only affects the orientation in instructions where the rotation parameter has not been specifically set. If an instruction has a specific rotation parameter, that is the one that is used.

The **^FW** instruction only affects fields that follow it. Once you have issued a **^FW** instruction, the setting is retained until you turn off the printer or send a new **^FW** instruction to the printer.

Remainder of Page Intentionally Left Blank

ZPL II BASICS

The **^PO** (Print Orientation) instruction inverts the label format 180 degrees. In essence, the label is printed upside down.

^PO

The format for the **^PO** instruction is:

^PO*x*

where

^PO = Set Print Orientation
x = Invert 180 degrees
N = normal **{I.V.P. = N}**
I = invert

Once you issue a **^PO** command, the setting is retained until you turn off the printer or send the opposite **^PO** instruction to the printer.

The **^POI** instruction moves the Label Home position to the furthest point away from the main frame. Therefore, a different **^LH** (Label Home) can be used to move the print back onto the label.

Note: If multiple **^PO** instructions are issued in the same label format, only the last instruction sent to the printer is used.

```
^XA^CFD
^POI
^LH330,10
^F050,50^FDZEBRA TECHNOLOGIES^FS
^F050,75^FDVernon Hills, IL
^XZ
```

```
ZEBRA TECHNOLOGIES
Vernon Hills, IL
```

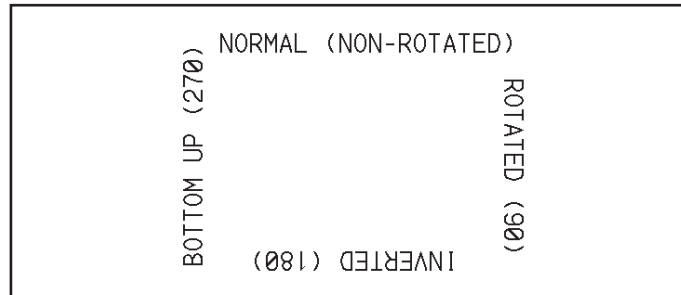

Defining Field Orientation Parameters

Field Definition Instructions

Field definition instructions define the field origin, field typeset, field data, field separation and field block parameters. They are presented here in the order in which they are normally used in a ZPL II script (where they usually have other instructions among them). Figure 2.1 (see Page 2-6) illustrates which parts of a label are controlled by the **^LH** instruction (previously discussed) and the **^FO** and **^FT** instructions.

The **^FO** (Field Origin) instruction sets a field origin, relative to the label home position designated by the **^LH** command. **^FO** sets the upper-left corner of the field area by defining points along the x-axis and y-axis independent of the rotation.

See the discussion on Understanding **^FO** and **^FT** on Page 2-17.

The format for the **^FO** instruction is:

^FO*x,y*

where

^FO	=	Set Field Origin
x	=	Number of dots along x-axis <i>Default value: = 0</i> <i>Acceptable values: 0 - 9999</i>
y	=	Number of dots along y-axis <i>Default value: = 0</i> <i>Acceptable values: 0 - 9999</i>

Note: If a the value for 'x' or 'y' is too big, it could position the field origin completely off the label.

^FO

The **^FT** (Field Typeset) instruction also sets the field position, relative to the home position of the label designated by the **^LH** command. The typesetting origin of the field is fixed with respect to the contents of the field and does not change with rotation.

See the discussion on Understanding **^FO** and **^FT** on Page 2-17.

The format for the **^FT** instruction is:

^FT

^FT*x,y*

where

- ^FT** = Set Field Typeset
- x** = Number of dots along x-axis
Default value: = Position after last formatted field.
Acceptable values: 0 - 9999
- y** = Number of dots along y-axis
Default value: = Position after last formatted text field.
Acceptable values: 0 - 9999

The following defines how **^FT** works for text, barcodes, graphic boxes, and images.

TEXT - Origin is the start of the character string, at the baseline of the font. Normally the baseline is the bottom of most characters except for those with descenders such as ‘g’, ‘y’, etc.

NOTE: When a coordinate is missing, the position following the last formatted field is assumed. This “remembering” simplifies field positioning with respect to other fields. Once the first field is positioned, other fields will follow automatically.

BAR CODES - The origin is the base of the bar code, even when an interpretation is present below the bar code, or if the bar code has guard bars.

GRAPHIC BOXES - Origin is at the bottom left corner of the box.

IMAGES - Origin is at the bottom left corner of the rectangular image area.

IMPORTANT NOTE

There are several instances where using the **^FT** instruction without specified “a” and “b” parameters is not recommended.

1. To position the first field in a label format.
2. At any time with the **^FN** (Field Number) instruction.
3. Following a **^SN** (Serialization Data) instruction.

Understanding ^FO and ^FT Instructions

FO is defined as the upper left corner of the print area. **FT** is defined as the bottom left of the printed field data.

The field position for both the **^FO** and **^FT** instructions are relative to the home position designated by the **^LH** instruction. However, the typesetting origin (**^FT**) does not change with respect to field content at different rotations whereas the field origin (**^FO**) does not change with the field area at different rotations.

The following is an example of how **^FO** differs from **^FT** for an inverted rotation.

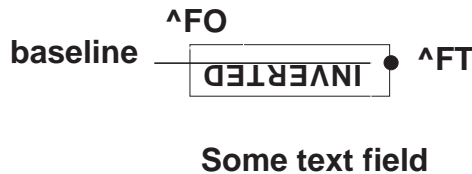

Note: **^FT** may be easier to use with rotated fields, since no matter what the rotation, only the fields start position needs to be calculated. Many fonts are “proportionally spaced” which makes calculating the length of the string for **^FO** positioning difficult. The **^FT** position allows several fields of various lengths to ‘start’ at the same position.

The **^FD** (Field Data) instruction defines the data string for the field. The field data can be any printable character *except* those used as instruction prefixes (i.e. ^ and ~). See Appendix A.

The format for the **^FD** instruction is:

^FD

^FD<data>

where

^FD = Enter Field Data

<data> = Data to be printed

Note 1: The **field data** string is limited to 3072 characters.

Note 2: The ^ and ~ characters can be printed by changing the prefix characters. See the **CC** and **CT** instructions in Section 7.
(*Note: The new prefix characters cannot be printed.*)

Note 3: Characters with codes above 127, or the ^ and ~ characters can be printed using the **^FH** and **^FD** instructions.

In the past, CR/LF (Carriage Return/Line Feed) were ignored in **^FD** statements. However, with the support for the **^B7** (PDF417 Bar Code) and the **^FB** (Field Block) instruction, CR/LF have become valid characters for all **^FD** statements.

The **^FS** (Field Separator) instruction denotes the end of the field definition. The field separator instruction can be issued as a single ASCII control code **SI** (Control-O, HEX 0F).

The format for the **^FS** instruction is:

^FS

^FS

where

^FS = Field Separator

The following are some examples of how the **^FO**, **^FD** and **^FS** instructions are used.

Example 1 for Using **^FO**, **^FD**, and **^FS**

Notice the values used for **^FO** and **^FD**.

<pre data-bbox="548 806 932 909">^XA^CFD ^F0100,100^FDZEBRA TECHNOLOGIES^FS ^F0100,125^FDVernon Hills, IL ^XZ</pre>	<pre data-bbox="1015 821 1208 863">ZEBRA TECHNOLOGIES Vernon Hills, IL</pre>
---	--

Example 2 for Using **^FO**, **^FD**, and **^FS**

Notice how the different values used for **^FO** and **^FD** changed the label.

<pre data-bbox="535 1333 915 1436">^XA^CFD ^F0250,250^FDZEBRA TECHNOLOGIES^FS ^F0150,175^FDVERNON HILLS, IL ^XZ</pre>	<pre data-bbox="1010 1337 1281 1421">VERNON HILLS, IL ZEBRA TECHNOLOGIES</pre>
---	---

Embedding HEX Codes in Field Data Statements

The **^FH** (Field HEX) instruction allows you to enter the hexadecimal value for any character directly into the **^FD** statement. The **^FH** instruction *must* precede each **^FD** instruction in which it will be used.

Within the **^FD** statement, the HEX indicator must precede each Hexadecimal value. The default HEX indicator is the underscore “_”. The ‘a’ parameter can be added when a different HEX indicator is needed.

This instruction can be used with any of the instructions that have field data (i.e. **^FD**, **^FV** (Field Variable), and **^SN** (Serialized Data)).

Valid HEX characters are:

0 1 2 3 4 5 6 7 8 9 A B C D E F a b c d e f

The format for the **^FH** instruction is:

^FHa

where

^FH = Field HEX Instruction

a = HEX indicator

{I.V.P. = _ (underscore)}

Other Acceptable values: Any character except current Format and Control prefix.

Example:

^FO100,100^AD^FH^FDTilde _7e used for HEX^FS

^FO100,100^AD^FH\^FDTilde \7E used for HEX^FS

Either of the above two lines will produce the following results.

Tilde ~ used for HEX

Field Block

^FB

The **^FB** (Field Block) instruction allows you to print text into a defined “block type ” format. This instruction formats an **^FD** text string into a block of text using the origin, font and rotation specified for the text string. This instruction also contains an automatic word wrap function.

The format for the **^FB** instruction is:

^FB

^FBa,b,c,d,e

where

- ^FB** = Define Field Block
- a** = Width of text block line in dots
Valid data: Minimum = one character width.
 Maximum = label width.
Acceptable values: 0 - 9999.
Default value: = 0.
Note: If value is less than font width or not specified, text block will not print.
- b** = Maximum number of lines in text block
Acceptable values: 1 - 9999.
Default value: 1 line.
Note: Text exceeding the maximum number of lines will overwrite the last line. Changing the font size will automatically increase or decrease the size of the block.
- c** = Add or delete space between lines in dots.
Acceptable values: -9999 to +9999
Default value: = 0
Note: Numbers are considered to be positive unless preceded by a minus sign. Positive values add space; negative values delete space.

- d** = Justification of text in block.
Acceptable values: L (Left), C (Center), J (Margin to Margin) and R (Right)
Default value: = L (Left)
Note: Last line is “left justified” if “J” is used.
- e** = Secondary left margin. How far in dots, second, and all remaining lines in text block will be indented.
Acceptable values: 0 - 9999

The following is an example of how the **^FB** instruction affects the field data.

**"FD" Statement
THAT IS Preceded
by an "FB"
instruction.**

The instructions to print the statement are as follows:

```
^XA^CF0,30,30^F050,25  
^FB250,4,,  
^FD "FD" Statement THAT IS Preceded by an "FB" instruction.  
^XZ
```

"FD" Statement NOT Preceded by an "FB" instruction.

The instructions to print the statement are as follows:

```
^XA^CF0,30,30^F050,50  
^FD "FD" Statement NOT Preceded by an "FB" instruction.  
^XZ
```

Notes concerning the ^FB instruction are on the next page....

Notes concerning the **^FB** instruction:

- * The following scheme can be used to facilitate special functions:

“ \& ” = carriage return/line feed
 “ \(*) ” = soft hyphen (word break with a dash)
 “ \\ ” = \ (See Item 1 below)

Item 1: **^CI13** must be selected in order to print a \.

Item 2: If a soft hyphen is placed near the end of a line, the hyphen will be printed. If it is not placed near the end of the line, it will be ignored.

(*) = Any alpha/numeric character.

- * If a word is too long to print on one line by itself (and no soft hyphen is specified), a hyphen will automatically be placed in the word at the right edge of the block. The remainder of the word will be on the next line. *(The position of the hyphen depends on word length not a syllable boundary. Placing a soft hyphen with a word controls where the hyphenation will occur.)*
- * Maximum data string length is 3K including control characters and carriage return/line feeds.
- * Normal carriage return/line feeds and ‘word spaces’ at line breaks are discarded.
- * When using **^FT (Field Typeset)**..... **^FT** uses the baseline origin of the last possible line of text. Increasing the font size will cause the text block to increase in size from bottom to top. (Could cause label to print past top of label.)
- * When using **^FO**..... Increasing the font size will cause the text block to increase in size from top to bottom.
- * If an **^SN** is used instead of an **^FD**, the field will not print.
- * An **^FS** terminates an **^FB** statement. Each block requires its own **^FB** instruction.

Introduction to Device Names

Device Names have been assigned to the various storage areas for ZPL II objects (graphic images, label formats, downloaded fonts, etc.) Device Names are used to identify the DRAM, RAM, EPROM, etc. This allows for Storage, Recall, Copy, and Deletion of ZPL II Objects to/from specific areas.

Each of these areas has been assigned a device name as a way of identification. The Device Name is a single letter followed by a colon. The defined devices are:

- R: Printer DRAM library (read/write)
- B: Optional memory (a card or factory installed)
- E: Extra added EPROM stored objects (read only)
- Z: Internal ZPL II stored object library (read only)

Several ZPL II instructions use these Device Names. The Device Name is an optional parameter with most ZPL II instructions. Its default is defined with the individual ZPL II instruction.

The default for the creation and deletion of objects is printer DRAM. For recalling of objects, the following search priority is used: DRAM, RAM, extra EPROM, internal ZPL II (R:, B:, E:, Z:, * or ? (All)).

Introduction to ZPL II Object Names and Extensions

Each ZPL II Object (graphic images, label format, etc.) must have a name. This name will consist of two parts: an Object Name and an Extension. Object names can be 1 to 8 alphanumeric characters in length. Extensions consist of a period followed by 3 *pre-defined* characters. Object name conventions and extensions are similar to MS-DOS [™] file name conventions and extensions.

Several ZPL II instructions use these object names. Object names have no default and must be supplied. Extensions have the defaults defined below. Depending on the ZPL II instruction, if an extension is missing, incomplete or incorrect, a default will be used.

Defined extensions for ZPL II Object names, along with their related ZPL II instructions are:

- .ZPL ZPL II label format (^DF or ^XF)
- .FNT fonts in Zebra format (~DB, ~DS, or ^XA)
- .GRF Zebra bitmap format (from ~DG, ^IS, ^IL, ^XG or ^IM)

Depending on the ZPL II instruction, the Object name and Extension may support the use of the asterisk (*) and question mark (?) as wild cards.

Using Device and Object Names with ZPL II Instructions

The Device Names and Object Names described on the previous page can be used with ZPL II instructions which support a name parameter. The instructions are:

- ~DG Download Graphic Image
- ^XG Recall Graphic Image
- ^IS Store format as a graphic image
- ^IL Load Image
- ^IM Move Image
- ^DF Store ZPL II format as text
- ^XF Recall ZPL II format
- ^ID Image Delete
- ^HW Host Directory List
- ^WD Print Directory
- ~DB Download Bitmap
- ~DS Download Scalable Font

The name parameter can consist of either an alphanumeric string of from 1 to 8 characters, or a string containing a Device Name followed by an Object Name with an Extension.

Defaults and/or use of the asterisk (*) and question mark (?) as wild cards will be defined with the individual instruction.

Defining and Using the AUTOEXEC.ZPL Function

An AUTOEXEC.ZPL file function is supported by the printer. It functions in much the same way as the autoexec.bat file in MS-DOS. It can be used for setting up various parameters at the time the printer is powered up (i.e. ^COY, ^LL, ^CWn, etc.). It can also be recalled at any time after power up.

This file must initially be in the extra EPROM. When the printer is powered on, it looks to the extra EPROM, for the stored format called AUTOEXEC.ZPL. If found, the contents of the file are automatically executed as a stored format.

Using Battery Powered Font Cards

~JB

The **~JB** (Reset Battery Dead) instruction is used for the following two conditions.

- 1) This instruction *must* be sent to the printer if the battery supplying power to the Battery Powered Font Card fails and is replaced. (A bad battery would show a “battery dead” condition on the Configuration Label.)

Note: If the battery is replaced and this instruction *is not sent* to the printer, the Battery Powered Font Card **will not** function.

- 2) To intentionally clear (re-initialize) the Battery Powered Font Card.

Printer Configuration

In most cases, the printer can be configured from either the front panel or through various ZPL II instructions. Once a configuration instruction is received by the printer, the change will usually affect the current label format and any future label formats until changed or the printer power is turned off. The next label printed will reflect the new instruction.

This section discusses how to use the ZPL II printer configuration instructions. The following is a list of these instructions.

- **^MM** (Print Mode) - Sets the printer to one of its four basic printing modes; Tear-Off, Rewind, Peel-Off and Cutter.
- **^MN** (Media Tracking) - Sets the printer for either Non-Continuous or Continuous media.
- **^MT** (Thermal Media) - Sets the printer for either Direct Thermal media or Thermal Transfer media.
- **^MD** (Media Darkness) - Adjust how dark the printing will be by adjusting the “burn temperature” of the printhead.
- **^LT** (Label Top) - Shifts printing up to 64 dot rows up or down from the current Label Home position.
- **^SS** (Set Media Sensor) - Allows the user to override all of the internal values established after running a media profile.
- **^MP** (Disable Mode Switch) - Used to disable the front panel Darkness, Position and Calibrate modes. (*Active on STRIPE Printers only.*)
- **^JZ** (Reprint After Error) - Reprints a label if it was partially or incorrectly printed due to an error condition.

PRINTER CONFIGURATION

- **^JU** (Configuration Update) - Allows the user to save the current settings.
- **^SZ** (Set ZPL) - Allows the user to select either the ZPL or ZPL II Programming Language.

Printer configuration instructions must have a parameter in order to be valid. Instructions with a missing or invalid parameter will be ignored.

Once a printer configuration instruction has been issued, it will stay in effect until the printer is powered down or it is changed by reissuing the instruction with a different set of parameters.

If you want to save the changes you made, there are two ways to do it.

- 1) After issuing the instructions to the printer, press the SETUP/EXIT key on the front panel two (2) times. SAVE CHANGES PERMANENT is displayed on the LCD. (You may have to press one of the black oval keys until the word PERMANENT is displayed.) Press the NEXT key. The words SAVING PERMANENT and then PRINTER READY will be displayed. The changes you made have been saved.)
- 2) Use the **^JUx** instruction.

For STRIPE[®] Printers only:

- 1) After issuing the instructions to the printer, press the MODE key on the front panel four (4) times and then press the PAUSE key. (*Sequence through the MODE Options until only the PAUSE LED is on.*)
- 2) Use the **^JUx** instruction.

Print Mode

The **^MM** (Print Mode) instruction determines the action the printer takes after a label or group of labels has been printed. There are four different modes of operation.

- 1) **Tear Off** - After printing, the label is advanced so that the web is over the tear bar. Label, with backing attached, can then be torn off manually.
- 2) **Rewind** - Label and backing are rewound on an (*optional*) external rewind device. The next label is positioned under the print head (no backfeed motion).
- 3) **Peel Off** - After printing, the label is partially separated from the backing. Printing stops until the label is completely removed. Backing is rewound using an internal *backing only* rewind spindle. (Note: Select only if printer is equipped with internal rewind spindle.)
- 4) **Cutter** - Web separating printed and next label is extended into the cutter mechanism. Label is cut. Blank label is pulled back into the printer so it can be printed.

The format for the **^MM** instruction is:

^MM

^MMx

where

^MM = Print Mode

x = Desired Mode

T = Tear Off

R = Rewind

P = Peel Off

C = Cutter

A = Reserved

(Instruction ignored if parameter missing or incorrect.)

{I.V.P. = Last permanent value saved}

Media Tracking

^MN

This **^MN** (Media Tracking) instruction tells the printer what type of media is being used (continuous or non-continuous) for purposes of tracking. There are two choices for this instruction:

- 1) **Continuous Media** - This media has no physical characteristic (i.e. a web, notch, perforation, etc.) to separate labels. Label Length is determined by the **^LL** instruction (described on Page 2-9).
- 2) **Non-Continuous Media** - This media has some type of physical characteristic (i.e. a web, notch, hole, etc.) to separate the labels.

The format for the **^MN** instruction is:

^MNx

where

^MN = Media Tracking

x = Media Being Used

Y = Non-Continuous Media

N = Continuous Media

(Instruction ignored if parameter missing or incorrect.)

{I.V.P. = Last permanent value saved}

Media Type

This **^MT** (Media Type) instruction selects the type of media being used in the printer. There are two choices for this instruction:

- 1) **Thermal Transfer Media** - This media uses a high carbon black or colored ribbon. The ink on the ribbon is bonded to the media.
- 2) **Direct Thermal Media** - The media is heat sensitive and requires no ribbon.

The format for the **^MT** instruction is:

^MTx



where

^MT = Media Type

x = Media Being Used

T = Thermal Transfer Media

D = Direct Thermal Media

(Instruction ignored if parameter missing or incorrect.)

{I.V.P. = Last permanent value saved}

Media Darkness

This **^MD** (Media Darkness) instruction adjusts the darkness relative to the current darkness setting. The minimum value is -30 and the maximum value is 30.

^MD

The format for the **^MD** instruction is:

^MDx

where

^MD = Media Darkness

x = -30 to 30 depending on the current value. (Positive values do not require a “+ ” sign to be entered.)
(Instruction ignored if parameter missing or incorrect.)
{I.V.P. = 0}

Examples for Using the ^MD Instruction

If the current value (value on configuration label) is 16, entering the instruction **^MD-9** would decrease the value to 7.

If the current value (value on configuration label) is 1, entering the instruction **^MD15** would increase the value to 16.

If the current value (value on configuration label) is 25, entering the instruction **^MD10** would only increase the value to 30 since that is the maximum value allowed.

Note: Each **^MD** instruction is treated separately with respect to the current value (value on configuration label).

For example, this is what would happen if two **^MD** instructions were received.

Assume the current value is 15. An **^MD-6** instruction is received that changes the current value to 9. Another instruction, **^MD2**, is received. The current value is changed 17. The two **^MD** instructions were treated individually with respect to the current value of 15.

Label Top Position

The **^LT** (Label Top) instruction moves the entire label format a maximum of 64 dot rows up or down from its current position with respect to the top edge of the label. A negative value moves the format towards the top of the label; a positive number moves the format away from the top of the label.

This instruction can be used to fine-tune the position of the finished label without having to change any of the existing parameters.

Note: This instruction does not change the Media Rest position.

The format for the **^LT** instruction is:

^LTx

^LT

where

^LT = Label Top

x = -64 to +64 dot rows.

(Positive values do not require a “+” sign to be entered.)

(Instruction ignored if parameter missing or incorrect.)

{I.V.P. = Last permanent value saved}

Set Media Sensors

The ^SS (Set Media Sensor) instruction is used to change the values for media, web, ribbon and label length that were set during the “media calibration” process. (The “Media Calibration” process is described in “Configuring to the Application” Section of the USER Guide.)

In the illustration below is an example of a Media Sensor Profile. Notice the numbers from 000 to 100 and where the words **WEB**, **MEDIA** and **RIBBON** appear in relation to those numbers. Also notice the black vertical spike. This represents where the printer sensed the transition from media-to-web-to-media.

Note: Media and Sensor Profile produced on your printer may look different than the one shown here.

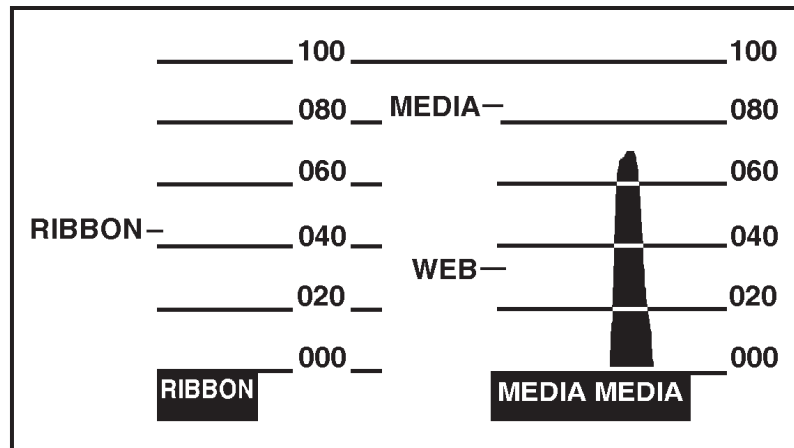

The format for the **^SS** instruction is:

^SSw, m, r, l, m2, r2

^SS

where

- ^SS** = Set Media Sensors
- w** = A 3-digit value for the web. (000 to 100)
Default value: Value shown on the media sensor profile or configuration label.
- m** = A 3-digit value for the media. (000 to 100)
Default value: Value shown on the media sensor profile or configuration label.
- r** = A 3-digit value for the ribbon. (000 to 100)
Default value: Value shown on the media sensor profile or configuration label.
- l** = A 4-digit value for the label length in dots. (0001 to 9999)
Default value: The value calculated in the “Calibration” process. (See the configuration label).
- m2** = A 3-digit value for intensity of media LED. (000 to 100)
Default value: The value calculated in the “Calibration” process. (See the configuration label).
- r2** = A 3-digit value for intensity of ribbon LED. (000 to 100)
Default value: The value calculated in the “Calibration” process. (See the configuration label).

{I.V.P. for all parameters = Last permanent value saved}

Note: The ‘m2’ and ‘r2’ values have no effect in Stripe Printers.

Mode Protection

Note: This instruction applies to STRIPE printers only.

The **^MP** (Mode Protection) instruction is used to disable the various Mode functions on the front panel. Once disabled, the settings for the particular mode function can no longer be changed and the LED associated with the function will not light.

^MP

Since this instruction has only one parameter, each mode will have to be disabled with an individual **^MP** instruction.

The format for the **^MP** instruction is:

^MPx

where

^MP = Mode Protection

x = Mode to Protect
Default value: No changes

Other acceptable values:

D = Disable Darkness Mode

P = Disable Position Mode

C = Disable Calibration Mode

E = Enable All Modes

S = Disable all Mode Saves. (Modes
can be adjusted but values will
not be saved.)

*(Instruction ignored if parameter missing or
incorrect.)*

Examples for Using the ^MP Instruction.

To disable the Darken Mode and the Calibrate Mode, the following must be sent to the printer.

^XA^MPD^MPC^XZ

Reprint After Error

The **^JZ** (Reprint After Error) instruction is used to reprint a partially printed label caused by a Ribbon Out, Media Out or Head Open error condition. The label will be reprinted as soon as the error condition is corrected.

This instruction will remain active until another **^JZ** instruction is sent to the printer or the printer is turned off.

The format for the **^JZ** instruction is:

^JZ

^JZx

where

^JZ = Reprint After Error

x = Reprint After Error
Y = Yes **{I.V.P.}**
N = No

(Instruction ignored if parameter missing or incorrect.)

The **^JZ** instruction sets the error mode for the printer. (If **^JZ** is changed, only labels after the change will be affected.)

Configuration Update

The **^JU** (Configuration Update) instruction sets the active configuration for the printer.

There are three choices for this instruction. They are defined as follows:

S = Save Current Settings

The current configuration will be saved. This is the configuration that will be used at Power-On.

F = Reload Factory Values (Default)

The factory values (default values) will be loaded. (These values will be lost at Power Off if they are not saved with the **^JUS** instruction.)

R = Recall Last Saved Values

The last values saved using this (**^JU**) instruction or the Mode Sequencing from the front panel will be loaded.

The format for the **^JU** instruction is:

^JU

^JUx

where

^JU = Configuration Update

x = Active Configuration

F = Reload Factory Defaults

R = Recall Last Saved Values

S = Save Current Settings

(Instruction ignored if parameter missing or incorrect.)

Set ZPL

The **^SZ** (Set ZPL) instruction is used to select the programming language used by the printer. This instruction gives you the ability to print labels formatted in both ZPL or ZPL II.

This instruction will remain active until another **^SZ** instruction is sent to the printer or the printer is turned off.

The format for the **^SZ** instruction is:

^SZ

^SZa

where

^SZ = Set ZPL
a = Set ZPL
1 = ZPL
2 = ZPL II

{I.V.P. = Last permanent value saved}

(Instruction ignored if parameter missing or incorrect.)

Setting Up Customized Configuration Formats

You can save a great deal of time by setting up your own configuration formats. If most of your printing is done on one or two types of media, you can easily create label formats specifically for those media.

If you need to change various instructions to print a special label, when you are finished you only need to change the media and load the appropriate configuration format.

Depending on your needs and specific application, the following is a list of the instructions you might want to put into a configuration format.

- ^XB** Suppress Backfeed
- ^PR** Print Rate
- ^LL** Label Length
- ^LT** Label Top
- ^MM** Print Mode
- ^MT** Thermal Media
- ^JZ** Reprint After Error
- ^SS** Set Media Sensor
- ^MD** Media Darkness
- ^MN** Media Tracking
- ^JU** Configuration Update
- ^SZ** Set ZPL

Note: You can have as many of these format configurations as you need. Just give them all a different name and send it to the printer when it is needed.

To print text on labels with the Zebra printer, one or more Printing Fonts must be selected. This chapter discusses the available Printing Fonts and the ZPL II instructions used to produce them.

Zebra Fonts

Most Zebra printers come standard with 8 bit-mapped fonts and one scalable font. Additional downloadable bit-mapped and scalable fonts are also available.

Character size and density (how dark it appears) depends on the density of the print head and the media used. Three different print heads are available, 6 dots/mm, 8 dots/mm and 12 dots/mm.

Internal bit-mapped fonts can be magnified from 2 to 10 times their normal (default) size. The magnification factor is in whole numbers. Therefore, if the normal size of a bit mapped font is 9 dots high and 5 dots wide, a magnification factor of 3 would produce a character of 27 dots high and 15 dots wide. Height and width can be magnified independently.

Understanding Bit-Mapped Font Magnification Factors

Many of the instructions in this chapter contain parameters for entering the height and width of printed characters. The values are always entered in dots. When entering these values for bit-mapped fonts, use the following formula.

Base Height x Magnification Factor = Height Parameter Value.
(Same principle applies to width.)

EXAMPLE:

Base height of bit map character is 9 dots.
Base width of bit map character is 5 dots.

To magnify the character 3 times,
the height parameter is 27
the width parameter is 15.

Note: For consistent results, always use the correct parameter values. See Tables 4.1 thru 4.5 on Pages 4-8 thru 4-10.

International Character Sets

Zebra printers can print all fonts using various international character sets: USA1, USA2, UK, Holland, Denmark/Norway, Sweden/Finland, Germany, France 1, France 2, Italy, Spain and miscellaneous. ZPL II follows the ISO standards for international characters.

The ^CI (Change International Font) instruction enables you to call up the international character set you want to use for printing. You can mix character sets on a label. The illustration below shows the international character sets available. The instruction to call an international character set is

^CIx

^CI

where

- ^CI** = Change International Font
- x** = Desired Character Set
 - 0 = USA1 **{I.V.P.}**
 - Other acceptable values:*
 - 1 = USA2 2 = UK 3 = Holland
 - 4 = Denmark/Norway 5 = Sweden/Finland
 - 6 = German 7 = France 1 8 = France 2
 - 9 = Italy 10 = Spain 11 = Miscellaneous
 - 12 = Japan 13 = IBM Code Page 850

Hex	2	3	4	5	5	5	5	6	7	7	7	7	
	3	0	0	B	C	D	E	0	B	C	D	E	
C10	#	0	@	[Φ]	^	'	{		}	~	
C11	#	0	@	½	ϕ	¾	^	'	¼	½	¾	~	
C12	£	0	@	[Φ]	^	'	{		}	~	
C13	f	0	§	[U]	^	'	{	ij	}	~	
C14	#	0	@	Æ	Ø	Å	^	'	æ	ø	å	~	
C15	Ü	0	É	Ä	Ö	À	U	é	ä	ö	à	ü	
C16	#	0	§	Ä	Ö	Ü	^	'	ä	ö	ü	β	
C17	£	0	à	[ç]	^	'	é	ì	ù	è	
C18	#	0	à	â	ç	é	î	ô	é	ù	è	û	
C19	£	0	§	[ç	é	^	ù	à	ò	è	ì	
C110	#	0	§	í	Ñ	¿	^	'	{	ñ	¿	~	
C111	£	0	É	Ä	Ö	Ü	^	'	ä	ë	ï	ö	ü
C112	#	0	@	[¥]	^	'	{		}	~	
C113	#	0	@	[\]	^	'	{		}	~	

International Character Sets

Text for Labels

Graphic Symbol Instruction

The **^GS** (Graphic Symbol) instruction enables you to generate the registered trademark and copyright symbols. The format for the graphic symbol instruction is:

^GSa,b,c

^GS

where

- ^GS** = Graphic Symbol
- a** = Font orientation
Default value: N = normal or last **^FW** value.
Other values:
 R = Rotate 90 degrees clockwise
 I = Inverted 180 degrees
 B = Bottom up, 270 degrees
- b** = Character height in dots proportional to width.
Default value: Last **^CF** value.
- c** = Character width in dots proportional to height.
Default value: Last **^CF** value.

Use the **^GS** instruction, then use **^FD** and the appropriate character (A thru E) within the field data statement to generate the character you want:

- A = ® (Registered Trade Mark)
- B = © (Copyright)
- C = ™ (Trade Mark)
- D = UL (Underwriters Laboratories approval)
- E = SPS (Canadian Standards Association approval)

```

^XA^CFD
^FO50,50^FDZEBRA PROGRAMMING^FS
^FO50,75^FD LANGUAGE II (ZPL II )^FS
^FO280,75^GS^FDC
^XZ
    
```

ZEBRA PROGRAMMING
LANGUAGE II (ZPL II™)

Font Selection

To use a text font, you must either use the change alphanumeric default font instruction (^CF) or specify an alphanumeric field instruction (^Ax).

Change Alphanumeric Default Font Instruction

You can use the ^CF (Change Alphanumeric Default Font) instruction to keep your programs simple. This instruction is:

^CFh,b,c

^CF

where

- ^CF** = Change Alphanumeric Default Font
- h** = Specified default font:
 A = font A **{I.V.P.}**
Other values: B thru H, and Ø-9.
 (Any font in the printer including downloaded fonts, EPROM stored fonts and fonts A-Z and 1-9 can be selected via ^CW.)
- b** = Individual character height in dots
Acceptable values: 0-9999 **{I.V.P. = 9}**
- c** = Individual character width in dots
Acceptable values: 0-9999 **{I.V.P. = 5}**

Parameter **h** specifies the default font for every alphanumeric field. Parameter **b** is default height for every alpha field, parameter **c** is default width value for every alpha field.

The default alphanumeric font is A. If you do not change the alphanumeric default font (**^CF instruction**), do not use any alphanumeric field instruction (**^Ax**) or enter an invalid font value, any data you specify will print in font A.

Defining *only* the height *or* width forces the magnification to be proportional to the parameter defined. If neither value is defined, the last ^CF values given or the default ^CF values for height and width are used.

Alphanumeric Font Instructions

The various **^Ax** (Select Alphanumeric Font) instructions are used to select the desired font. The three parameters associated with this instruction are used to define the font rotation, character height, and character width.

The format for the **^Ax** instruction is:

^Ax

^Axa,b,c

where

- ^A** = Alphanumeric Font
- x** = Desired bit-mapped font;
Instruction ignored if value is incorrect or not specified.
Other values: A thru Z, and Ø-9.
(Any font in the printer including downloaded fonts, EPROM stored fonts and fonts A-Z and 1-9 can be selected via **^CW**.)
- a** = Font orientation;
Default value: **^FW** default or last **^FW** value.
Other values:
N = Normal
R = Rotated, 90 degrees clockwise;
I = Inverted, 180 degrees
B = Read from Bottom up, 270 degrees
For Bit-Mapped Fonts
- b** = Character height in dots;
Default value: Standard matrix height for specified bit-mapped font
Other values: Multiples of height from 2 to 10 times the standard height in increments of 1.
- c** = Character width in dots;
Default value: Standard matrix height for specified bit-mapped font
Other values: Multiples of width from 2 to 10 times the standard width in increments of 1.

TEXT FOR LABELS

For Scalable fonts

- b** = Character height in dots;
Default value: 10 dots or last **^CF** value.
Other values: 10 thru 1500 depending on cache/character size.
- c** = Character width in dots;
Default value: 10 dots or last **^CF** value.
Other values: 10 thru 1500 depending on cache/character size.

Example for Using ^Ax Instruction

```
^XA  
^F050,50^ADN,36,20^FDZEBRA^FS  
^F050,100^ADN,36,20^FDPROGRAMMING^FS  
^F050,150^ADN,36,20^FDLANGUAGE II  
^XZ
```

```
ZEBRA  
PROGRAMMING  
LANGUAGE II
```

TEXT FOR LABELS

Default Fonts and Font Matrices

Font	Matrix	Type*	Character Size			
	HxW (in dots)		HxW (in in.)	char. /in.	HxW (in mm)	char. /mm
A	9 x 5	U-L-D	.059 x .039	25.4	1.50 x 0.99	1.01
B	11 x 7	U	.072 x .059	16.9	1.82 x 1.50	0.66
C,D	18 x 10	U-L-D	.118 x .079	12.7	2.99 x 2.00	0.50
E	21 x 10	OCR-B	.138 x .085	11.7	3.50 x 2.16	0.46
F	26 x 13	U-L-D	.170 x .105	9.53	4.32 x 2.67	0.37
G	60 x 40	U-L-D	.394 x .315	3.18	10.0 x 8.00	0.125
H	17 x 11	OCR-A	.111 x .098	10.20	2.81 x 2.48	0.40
GS	24x24	SYMBOL	.157 x .157	6.35	3.98 x 3.98	.251
∅	DEFAULT: 15x12	SCALABLE See SCALABLE FONT SIZE "Page 4-12.				

*U = Uppercase L = Lowercase D = Descenders

Table 4.1 Font Matrices (6 dot/mm print head)

Font	Matrix	Type*	Character Size			
	HxW (in dots)		HxW (in in.)	char. /in.	HxW (in mm)	char. /mm
A	9 x 5	U-L-D	.044 x .030	33.3	1.12 x 0.76	1.31
B	11 x 7	U	.054 x .044	22.7	1.37 x 1.12	0.89
C,D	18 x 10	U-L-D	.089 x .059	16.9	2.26 x 1.50	0.66
E	28 x 15	OCR-B	.138 x .098	10.2	3.50 x 2.49	0.40
F	26 x 13	U-L-D	.128 x .079	12.7	3.25 x 2.00	0.50
G	60 x 40	U-L-D	.295 x .197	4.2	7.49 x 5.00	0.167
H	21 x 13	OCR-A	.103 x .093	10.8	2.61 x 2.36	0.423
GS	24x24	SYMBOL	.118 x .118	8.5	2.99 x 2.99	0.334
∅	DEFAULT: 15x12	SCALABLE See SCALABLE FONT SIZE "Page 4-12.				

*U = Uppercase L = Lowercase D = Descenders

Table 4.2 Font Matrices (8 dot/mm print head)

TEXT FOR LABELS

Font	Matrix	Type *	Character Size			
	HxW (in dots)		HxW (in in.)	char. /in.	HxW (in mm)	char. /mm
A	9 x 5	U-L-D	.030 x .020	50.8	0.75 x 0.50	2.02
B	11 x 7	U	.036 x .030	33.8	0.91 x 0.75	1.32
C,D	18 x 10	U-L-D	.059 x .040	25.4	1.50 x 1.00	1.00
E	42 x 20	OCR-B	.138 x .085	23.4	1.75 x 1.08	0.92
F	26 x 13	U-L-D	.085 x .053	19.06	2.16 x 1.34	0.74
G	60 x 40	U-L-D	.197x .158	6.36	5.00 x 4.00	0.25
H	34 x 22	OCR-A	.111 x .098	10.20	2.81 x 2.48	0.40
GS	24x24	SYMBOL	.079 x .079	12.70	1.99 x 1.99	0.52
Ø	DEFAULT: 15x12	SCALABLE See SCALABLE FONT SIZE "Page 4-12.				

*U = Uppercase L = Lowercase D = Descenders

Table 4.3 Font Matrices (12 dot/mm print head)

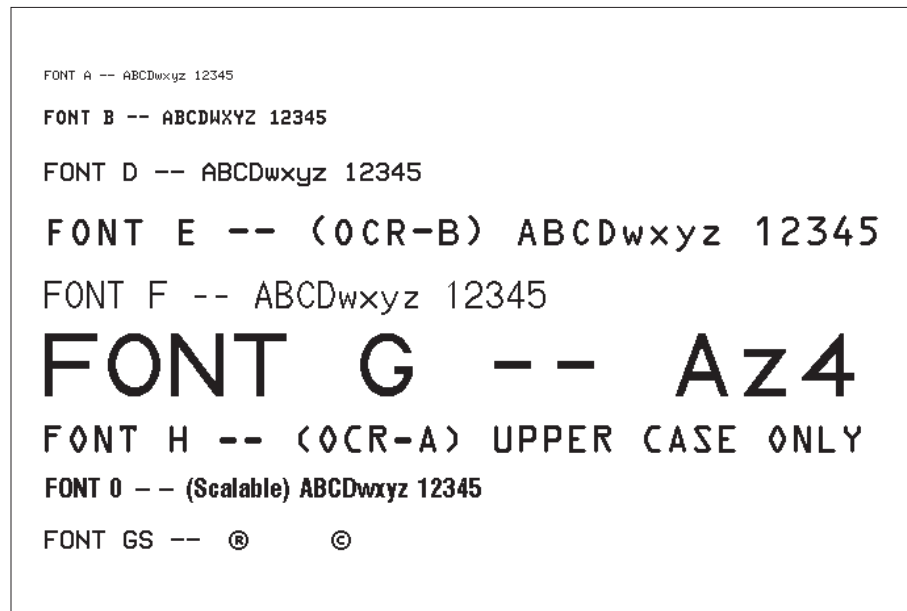

Figure 4.1 Standard Printer Fonts

TEXT FOR LABELS

Font	Matrix	Type *	ICG and Baseline	
	HxW (in dots)		Intercharacter Gap (in dots)	Baseline (in dots)
A	9 x 5	U-L-D	1	7
B	11 x 7	U	2	11
C,D	18 x 10	U-L-D	2	14
E	28 x 15	OCR-B	5	23
F	26 x 13	U-L-D	3	21
G	60 x 40	U-L-D	8	15
H	21 x 13	OCR-A	6	21
GS	24x24	SYMBOL	PROPORTIONAL	3 x HEIGHT/4
∅	DEFAULT: 15x12		PROPORTIONAL	3 x HEIGHT/4

Table 4.4 Intercharacter Gap and Baseline Parameters

Proportional Spacing

Proportional spacing is different than fixed spacing. In Table 4.4, the Intercharacter Gap (space between characters) is constant for fonts A thru H. The spacing between all characters is the same. For example, the spacing between 'MW' is the same as between 'IE.'

The baseline is the imaginary line on which the bottom (base) of all characters (except any descenders) rest. The area between the baseline and the bottom of the matrix is used for any character "descenders." Baseline numbers given in Table 4.4 define where the baseline is located in relationship to the top of the matrix. For example, the baseline for font 'E' is 23 dots down from the top of the matrix.

Bit-Map Font Size

Alphanumeric field instruction parameters *b* and *c* control the magnification and therefore, the ultimate size, of the font. The parameter is specified in dots, but ZPL II actually uses an integer multiplier times the original height/width of the font. For example, if you specify

^AD,54

you get characters three times their normal size (54 dots high), but if you specify

^AD,52

you get the same result (not characters 52 dots high).

Defining only the height or width forces the magnification to be proportional to the parameter defined. If neither is defined, the ^CF height and width are used. For example, if the height is twice the standard height, the width will be twice the standard width.

Note: If a ^CF instruction, with height and width parameters defined, is used to set the first font, any ^Ax instructions (to select a different font) that follow must have the height and width parameter filled in. If this is not done, the newly selected font will be magnified using values for the ^CF height and width parameters. The following is an example of what happens.

<pre> ^XA ^F050,50^CFD,26,10^FDZEBRA...^FS ^F050,100^FD"Bar Code, Bar None"^FS ^F050,200^AA^FDZEBRA...^FS ^F050,250^FD"Bar Code, Bar None" ^XZ </pre>	<pre> ZEBRA... "Bar Code, Bar None" ZEBRA... "Bar Code, Bar None" </pre>
---	---

Scalable Font Size

The **^AØ** (Scalable font) instruction is used with the built-in scalable font (**AØ** = CG Triumvirate Bold Condensed ®). Scalable fonts (also known as smooth vector fonts) expand the character size horizontally, vertically or in both dimensions on a dot by dot basis.

(Not applicable to Zebra STRIPE S-300 Printers.)

The built-in scalable font (**AØ**) defaults to no rotation, a character height of 15 dots and a character width of 12 dots. The printer will attempt to print a scalable font based upon the rotation, height in dots and width in dots parameters used with the **^AØ** instruction.

The format for the **^AØ** instruction is

^AØa,b,c

^AØ

where

- ^AØ** = Scalable Alphanumeric font
- a** = Font orientation;
Default value: N= normal or last **^FW** value.
Other values:
 R = Rotated, 90 degrees clockwise;
 I = Inverted, 180 degrees
 B =Read from Bottom up, 270 degrees.
- b** = Character height in dots;
Default value: 15 dots or last **^CF** value.
Acceptable values: 10 - 1500 dots
- c** = Character width in dots;
Default value: 12 dots or last **^CF** value.
Acceptable values: 10 - 1500 dots

Example for Using **^AØ** Instruction

```

^XA
^F050,50^A0,32,25^FDZEBRA^FS
^F050,150^A0,32,25^FDPROGRAM^FS
^F050,250^A0,32,25^FDLANGUAGE II
^XZ
```



Differences Between Download Scalable Fonts and Bitmap Fonts

For scalable fonts, setting the height and width equally produces the most balanced looking characters. Balanced characters are very pleasing to the eye since actual height and width are approximately equal to each other. This is achieved through the use of a smooth-scaling algorithm in the printer.

In the case of a bitmap font this balancing is built into the font. In actuality, the height of a bitmap font is slightly larger than the width. Bitmap fonts are always at the maximum size of the characters cell.

The standard Zebra font is Code Page 850 for character values greater than 20 HEX. There are six HEX character values below 20 HEX that are also recognized. The following chart shows how these character values are printed.

Note: Unidentified character values *should* default to a space.

A HEX	1a	will print a	0 (numeric)
A HEX	1b	will print a	½
A HEX	1c	will print a	⅔
A HEX	1d	will print a	U
A HEX	1e	will print a	ij
A HEX	1f	will print a	\

Cache On

The **^CO** (Cache On) instruction is used to change the size of the character cache. By definition, a “character cache” (from here on referred to as cache) is a portion of the DRAM reserved for storing scalable characters. All printers have a default 22K cache that is *always* turned on. The maximum single character size that can be stored, without changing the size of the cache, is 450 dots x 450 dots.

There are two types of fonts used in Zebra printers: bit-mapped and scalable. Letters, numbers, and symbols in a bit-mapped font have a fixed size. For example 10 points, 12 points, 14 points, etc. On the other hand, scalable fonts are not fixed in size. Their size is user selectable.

Because their size is fixed, bit-mapped fonts can be moved quickly to the label. By contrast, scalable fonts are much slower because each character is built on an as-needed basis before it is moved to the label. By storing scaled characters in a “cache” they can be recalled at a much faster speed.

The number of characters that can be stored in the cache depends on two factors; the size of the cache (memory) and the size of the character (in points) being saved. The larger the point size, the more space in the cache it uses. The default cache stores every scalable character that is requested for use on a label(s). If the same character, with the same rotation and size is used again, it is quickly retrieved from the cache.

It is quite possible that after a while, the print cache could become full. Once this happens space for new characters is obtained by eliminating an existing character from the print cache. Existing characters are eliminated by determining how often they have been used. This is done automatically. For example, a 28 point “Q” that was used only once would be a good candidate for elimination from the cache.

Maximum size of a single print cache character is 1500 dots x 1500 dots. It would require a cache of 300K for this.

When the cache is too small for the desired style, smaller characters may appear but larger characters will not. If possible, increase the size of the cache.

Note: The cache can be resized as often as needed. Any characters in the cache when it is resized are lost. Memory used for the cache reduces the space available for label bitmaps, graphics, downloaded fonts, etc.

The format for the **^CO** instruction is:

^COa,n

^CO

where:

- ^CO** = Cache On
- a** = Turn Cache On
Default value: Y=Yes
Other value: N=No
- n** = Amount of additional 'K of memory' to be added to cache. (*Default is 40K if no number specified.*)

The following is an example using the **^CO** instruction.

To resize the print cache to 62K:

^COY 40K (default memory) + 22K (existing cache) = 62K

To resize the print cache to 100K:

^COY,78 78K (memory added) + 22K (existing cache) = 100K

Notes on Print Cache Performance

Note 1: For printing large characters, memory added to the cache by the **^CO** instruction is not physically added to the 22K cache already in the printer. In the second example above, the resultant 100K cache is actually two separate blocks of memory, 22K and 78K.

Since large characters need contiguous blocks of memory, a character requiring a cache of 90K would not be completely stored because neither portion of the 100K cache is big enough. Therefore, if large characters are needed, the **^CO** instruction should reflect the actual size of the cache you need.

Note 2: Increasing the size of the cache will improve the performance in printing scalable fonts. However, the performance will start to go down if the size of the cache becomes large and contains too many characters. The performance gained will be lost because of the time involved in searching through the cache for all of the characters.

Download Bitmap Font

The **~DB** (Download Bitmap Font) instruction sets the printer to receive a downloaded bitmap font, defines native cell size, base-line, space size and copyright.

This instruction consists of two portions, a ZPL II instruction which defines the font and a structured data segment which defines each character of the font.

The format for the **~DB** instruction is:

~DB

**~DB<{Dst:}>Objectname<{.ext}>,a,h,w,base,space,
of characters,copyright,DATA**

where:

- ~DB=** Set printer to accept download bitmap font
- {Dst:}=** Destination device to store font
{Fixed. Will always be DRAM(R:)}
- Object=** Name of font, 1-8 alphanumeric characters
Default: Unknown.
- name**
- {.ext}=** Extension, 3 alphanumeric characters
{Fixed. Will always be .FNT}
- .ext}**
- a=** Orientation of native font
(N=Normal=default, R=90, I=180, B=270)
Currently, only N is supported.
- h=** Maximum height of cell in dots.
- w=** Maximum width of cell in dots.
- base=** Dots from top of cell to character baseline.
- space=** Width of space or nonexistent characters
- # char=** Number of characters in font *(This MUST match the number of characters being downloaded.)*
- copyright=** Holder of copyright. *(Maximum length of text string is 63 characters.)*

Format continued on next page.

DATA= Structured ASCII data which defines each character in the font. The # symbol signifies character code parameters which are separated with periods. The character code is from 1 to 4 characters to allow for large international character sets to be downloaded to the printer.

The data structure is:

#xxxx.h.w.x.y.i. data

where:

#xxxx = character code

h = bitmap height (in dot rows)

w = bitmap width (in dot rows)

x = x-offset (in dots)

y = y-offset (in dots)

i = typesetting motion displacement (width including inter-character gap of a particular character in the font)

data = HEX bitmap description

The following is an example of how to use the **~DB** instruction. It shows the first two characters of a font being downloaded to DRAM.

~DBR:TIMES.FNT,N,5,24,3,10,2,ZEBRA 1992,

#0025.5.16.2.5.18.

O0FF

O0FF

F000

F000

FFFF

#0037.4.24.3.6.26.

O0FF00

OFOOFO

OFOOFO

O0FF00

Downloadable Scalable Fonts

All dot parameters used in the instructions to create Scalable Fonts are translated into a point size. The printer will convert the dot parameter to some “point” size, since scalable fonts work in point sizes, not dots.

To determine how many dots must be entered to obtain a particular point size, use the following formula:

$$Dots = \frac{(Point\ Size) \times (Dots\ Per\ Inch\ of\ Printer)}{72}$$

For printers using a 6 dot/mm print head the “dots per inch of printer” value is 152.4.

For printers using a 8 dot/mm print head the “dots per inch of printer” value is 203.

For printers using a 12 dot/mm print head the “dots per inch of printer” value is 304.8.

Note: Actual point size will be an approximate value.

The actual height and width of the character in dots will vary, depending on font style and the particular character. Therefore, some characters will be smaller and some will be larger than the actual dot size requested.

The base lines for all scalable fonts are now calculated against the dot size of the cell. The base line will be 3/4 down from the top of the cell. For example, if the size of the cell is 80 dots, the base line will be 60 dots (3/4) down from the top of the cell.

Download Scalable Font

The **~DS** (Download Scalable Font) instruction is used to set the printer to receive a downloadable scalable font and defines the size of the font in bytes.

The **~DS** instruction, and its associated parameters, are the result of converting a vendor supplied font for use on a Zebra printer. The conversion is done using the Zebra Tools Utility Program called ZFONT. The utility program is available from Zebra Technologies.

~DS

The format for the **~DS** instruction is:

~DS {Dst:}Objectname{.ext},size,DATA

where:

- ~DS=** Set printer to accept download soft scalable font.
- {Dst:}=** Destination device to store font
Default value: R:(DRAM)
Other value: B:(Optional Memory)
- Objectname=** Name of font, 1-8 alphanumeric characters
Default: Unknown.
- {.ext}=** Extension, 3 alphanumeric characters
{Fixed. Will always be .FNT}
- size=** Size of font in bytes
(**Note:** This number was generated by the ZFONT program. It should not be changed.)
- DATA=** ASCII Hex string which defines the font.
(**Note:** This data was generated by the ZFONT program. It should not be changed.)

The following example shows the first three lines of a converted scalable font that is ready to be downloaded to the printer. If necessary the destination and objectname can be changed.

~DSB:CGTIMES.FNT,37080,

OOFFOOFFOOFFOOF
FFOAECB28FFFOOFF

Note: Downloaded scalable fonts are not checked for integrity. If they are corrupted, they will cause unpredictable results at the printer.

Font Identifier

All built-in fonts have a one-character identifier i.e. A, B, C, etc. The **^CW** (Font Identifier) instruction assigns a single alphanumeric character (A to Z and 0 to 9) to a font downloaded to DRAM R:, MEMORY CARD B:, EPROM E:, or BUILT-IN Z:.

If the assigned character is the same as that of a built-in font, the downloaded font is used in place of the built-in font. The new font will be printed on the label wherever the format calls for the built-in font. If used in place of a built in font, the change is only in effect until Power Off.

If the assigned character is different, the downloaded font is used as an additional font. The assignment will remain in effect until a new instruction is issued or the printer turned off.

The format for the **^CW** instruction is:

^CW <Internal>, {Src:}

^CW

where:

- ^CW** = Font Identifier. Use new font for ZPL II calls.
- Internal** = The letter of the built-in font to be substituted or the new font to be added. (*A required* one character entry.)
- {Src:}** = Source device where font is stored. (*Optional. Default is R:*)
- Font name** = The name of the downloaded font to be substituted for the built-in font or as an additional font. (Extension fixed at .FNT.) *Default: Unknown.*

Examples can be found on the next page.

TEXT FOR LABELS

The following are some examples of using the **^CW** instruction.

To use MYFONT.FNT stored in DRAM, whenever a format calls for Font A:

```
^XA^CWA,R:MYFONT.FNT^XZ
```

To use MYFONT.FNT stored in DRAM, as additional font Q:

```
^XA^CWQ,R:MYFONT.FNT^XZ
```

To use NEWFONT.FNT stored in DRAM, whenever a format calls for Font F:

```
^XA^CWF,R:NEWFONT.FNT^XZ
```

Zebra printers can print the following kinds of bar codes: ANSI Codabar, Code 11, Code 39, Code 49, Code 93, Code 128 (subsets A, B, and C), EAN-8, EAN-13, Industrial 2 of 5, Interleaved 2 of 5, LOGMARS, MSI, PDF417, Plessey, PostNet, Standard 2 of 5, UPC-A, UPC-E and UPC/EAN Extensions. For specific information about any one of these kinds of bar codes, refer to the specific bar code instruction.

Basic Format for Bar Codes

The basic format for bar codes is: quiet zone, start character, data, check digit, stop character and quiet zone. Refer to Figure 5.1. Not all bar codes require each of these elements.

Every bar code requires a *quiet zone*. A quiet zone (sometimes called a “clear area”) is an area adjacent to the machine-readable symbols that ensure proper reading (decoding) of the symbols. No printing is permissible within this area. Preprinted characters, borders, and background color are acceptable if they are invisible to the reading device; these are used in some applications but restricts the type of reading device that can be used. The size of the quiet zone depends on the size of bar widths (usually 10 times the width of the narrow bar).

Every bar code contains data made up of a sequence of light spaces and dark bars that represent letters, numbers, or other graphic characters. The usable characters differ among the various kinds of bar codes. Each bar code section in this chapter provides a table of applicable characters.

Start and stop characters and check digits are used by many, but not all, bar codes. These will be indicated in the specific bar code discussions.



Figure 5.1 Sample Bar Code

Bar Code Field Instructions

To create a bar code, a bar code field instruction must be contained in the label format. Table 5.1 shows all of the bar code field instructions. The number in brackets denotes the print ratio. Each instruction produces a unique bar code.

^B1	Code 11 (USD-8)	[2.0 - 3.0]
^B2	Interleaved 2 of 5	[2.0 - 3.0]
^B3	Code 39 (USD-3 & 3 of 9)	[2.0 - 3.0]
^B4	Code 49 (*)	[Fixed]
^B7	PDF417 (*)	[Fixed]
^B8	EAN-8 (*)	[Fixed]
^B9	UPC-E (*)	[Fixed]
^BA	Code 93 (USS-93) (*)	[Fixed]
^BC	Code 128 (USD-6) (*)	[Fixed]
^BE	EAN-13 (*)	[Fixed]
^BI	Industrial 2 of 5	[2.0 - 3.0]
^BJ	Standard 2 of 5	[2.0 - 3.0]
^BK	ANSI Codabar (USD-4 & 2 of 7)	[2.0 - 3.0]
^BL	LOGMARS	[2.0 - 3.0]
^BM	MSI	[2.0 - 3.0]
^BP	Plessey	[2.0 - 3.0]
^BS	UPC/EAN Extensions (*)	[Fixed]
^BU	UPC-A (*)	[Fixed]
^BZ	PostNet (*)	[Fixed]

(*) *Fixed Printing Ratio* - This means that the ratio between the width of the bars in the code is a fixed standard and cannot be changed.

Table 5.1 Available Bar Codes

Additionally, each bar code field instruction can be issued with a definition parameter string. The parameter string defines field rotation, height, and interpretation line status for all bar codes. For some bar codes, the parameter string also sets a check digit, start character, and/or stop character. Use the definition parameter string to command the printer to print bar codes of appropriate heights and densities that conform to the specifications of the application.

The use of the parameter string is optional since all parameters have default values. If the default values for all of the bar code parameters suit the application, then only the Bar Code instruction needs to be entered.

Parameters in bar code field instructions are 'position-specific.' If a value (other than the default value) is manually entered for one parameter, a comma “,” (the ZPL II delimiter character) must be used to mark the position of the preceding parameters in the string.

To change just the third parameter, enter two commas and then the value for the third parameter. The default values will be automatically used for the first and second parameters. The following is an example of how this would actually be entered in the ZPL II label format.

For example, a bar code field instruction is selected that has four parameters. The second parameter defines the height of the bar in dots. The bar code is to be printed using default values for all the parameters EXCEPT the height of the bar. This is to be 50 dots. The instruction would be entered as follows: (where *x* is the value for one of the bar codes.)

^**Bx,50** (where *Bx* is one of the bar codes in Table 5.1)

Note: Notice that no comma was entered to mark the position of the third and fourth parameters. Delimiters (commas) are not required for parameters between a manually entered value and the end of the parameter string.

Typical Instructions for Printing a Bar Code

To print a bar code as part of a label, the following instructions will be required to appear in the ZPL II program.

^FO	
or ^FT	Field Position instruction
^Bx	A Bar Code instruction
^FD	Field Data instruction (start of bar code data)
data	1234ABF
^FS	Field Separator instruction (end of bar code data)

Note: The **^BY** might also be included if the physical characteristics such as bar height, bar width, and wide to narrow bar ratio need to be changed.

The bar code instructions are organized into four groups. Each group represents a particular type of bar code. These groups and the bar codes they contain are as follows:

NUMERIC-ONLY BAR CODES

^B1 Code 11
^B2 Interleaved 2 of 5
^BI Industrial 2 of 5
^BJ Standard 2 of 5
^BK ANSI Codabar (or NW-7)
^BM MSI
^BP Plessey
^BZ POSTNET

RETAIL LABELING BAR CODES

^B8 EAN-8
^B9 UPC-E
^BE EAN-13
^BS UPC/EAN extensions
^BU UPC-A

ALPHANUMERIC BAR CODES

^B3 Code 39
^BA Code 93
^BC Code 128
^BL LOGMARS

TWO-DIMENSIONAL BAR CODES

^B4 Code 49
^B7 PDF417

Each bar code discussed in this chapter is accompanied by a printed example of the bar code and the instructions sent to the Zebra printer to produce the bar code. A table containing printable characters, control characters, and start/stop characters associated with the code is also included.

Field Default Instructions

Bar Code Field Default Instruction

^BY

The **^BY** instruction is used to change the values for the Narrow Element Module (Narrow Bar or Space) Width, the Wide Bar to Narrow Bar Width Ratio and the Bar Height. It can be used as often as necessary within a label format.

The format for the **^BY** instruction is:

^BYi,j,b

where

^BY = Change Bar Code Default Parameters

i = Module (Narrow Bar) Width
Initial power -up value: 2 dots
Acceptable values: 1-10 dots

j = Wide Bar to Narrow Bar Width Ratio
Initial power-up ratio: 3.0
Acceptable ratios: From 2.0 to 3.0 in .1 increments.
(No affect on Fixed Ratio bar codes.)

b = Height of bars
Initial Power-up value: 10 dots,
Acceptable values: 1 dot to height of label

For parameter **j**, the actual ratio generated is a function of the number of dots in parameter **i**, narrow bar (module). See Table 5.2 Bar Code Print Ratios.

For example, select module width **i** at 9 and the ratio **j** at 2.4. The width of the narrow bar is 9 dots wide and the wide bar is 9 x 2.4 or 21.6 dots. However, since the printer rounds out to the nearest dot, the wide bar is actually printed at 22 dots.

This produces a bar code with a ratio of 2.44 (22 divided by 9). This ratio is as close to 2.4 as possible since only full dots are printed.

Module width and height (parameters **i** and **b**) may be changed at anytime with the **^BY** instruction regardless of the symbology selected.

BAR CODES

Ratio Selected (j)	Module Width in Dots (i)									
	1	2	3	4	5	6	7	8	9	10
2.0	2:1	2:1	2:1	2:1	2:1	2:1	2:1	2:1	2:1	2:1
2.1	2:1	2:1	2:1	2:1	2:1	2:1	2:1	2:1	2:1	2.1:1
2.2	2:1	2:1	2:1	2:1	2.2:1	2.16:1	2.1:1	2.12:1	2.1:1	2.2:1
2.3	2:1	2:1	2.3:1	2.25:1	2.2:1	2.16:1	2.28:1	2.25:1	2.2:1	2.3:1
2.4	2:1	2:1	2.3:1	2.25:1	2.4:1	2.3:1	2.28:1	2.37:1	2.3:1	2.4:1
2.5	2:1	2.5:1	2.3:1	2.5:1	2.4:1	2.5:1	2.4:1	2.5:1	2.4:1	2.5:1
2.6	2:1	2.5:1	2.3:1	2.5:1	2.6:1	2.5:1	2.57:1	2.5:1	2.5:1	2.6:1
2.7	2:1	2.5:1	2.6:1	2.5:1	2.6:1	2.6:1	2.57:1	2.65:1	2.6:1	2.7:1
2.8	2:1	2.5:1	2.6:1	2.75:1	2.8:1	2.6:1	2.7:1	2.75:1	2.7:1	2.8:1
2.9	2:1	2.5:1	2.6:1	2.75:1	2.8:1	2.8:1	2.85:1	2.87:1	2.8:1	2.9:1
3.0	3:1	3:1	3:1	3:1	3:1	3:1	3:1	3:1	3:1	3:1

Table 5.2 Bar Code Print Ratios

Note 1: Once a **^BY** instruction is entered into a label format, it stays in effect until the another **^BY** instruction is encountered.

Note 2: Parameter *b* in the **^BY** instruction is overridden by the *b* parameter in any bar code that comes after the **^BY** instruction.

Each bar code described in this chapter contains an example of the bar code and the ZPL II instructions used to create it. Although they are not shown, if you want to print out the bar code on your printer, remember to use the Label Format Bracket instructions (**^XA** and **^XZ**) described on Page 2-6.

Note: Bar codes shown in the examples were printed using **^BY3** parameters for clarity. Depending on the print head used in your printer and/or your **^BY** settings, your bar codes may appear larger or smaller than those shown here

Numeric-Only Bar Codes

Code 11 Bar Code

^B1

The **^B1** (Code 11) bar code instruction is also known as USD-8 code.

In a Code 11 bar code, each character is composed of three bars and two spaces, and the character set includes 10 digits plus a dash.

Print Ratios Supported: 2.0 to 3.0.

^FD (Field Data) Limitations: 100+ characters. Actual amount of data depends on ^BY ratio and width (length if rotated) of label.

Figure 5.2 shows an example of the Code 11 bar code and the instructions used to print it. Table 5.3 shows all of the characters associated with this bar code.



Figure 5.2 Code 11 Bar Code

<u>Characters</u>	
0	1
2	3
4	5
6	7
8	9
—	
<u>Internal Start/Stop Character</u>	
△	

Note: When used as a stop character
 △ is used with 1 check digit
 △ is used with 2 check digits

Table 5.3 Code 11 Characters

BAR CODES

The format for the **^B1** instruction is:

^B1a,e,b,f,g

where

- ^B1** = Code 11 bar code
- a** = Field Position
Default value: Current **^FW** setting
Other values:
 - R= Rotated (90 Degrees Clockwise)
 - I = Inverted (180 Degrees)
 - B= Bottom Up (270 Degrees - Read from bottom up)
- e** = Check Digit
Default value: N(No) = 2 digits
Other value: Y(Yes) = 1 digit
- b** = Bar Code Height
Default value: Value set by **^BY**.
Other values: 1 dot to 9999 dots.
- f** = Print Interpretation Line
Default value: Y=Yes
Other value: N=No
- g** = Print Interpretation Line Above Code
Default value: N=No
Other value: Y=Yes

Interleaved 2 of 5 Bar Code

^B2

The **^B2** (Interleaved 2 of 5) bar code instruction is a high density, self-checking, continuous, numeric symbology.

Each data character for the Interleaved 2 of 5 bar code is composed of five elements: five bars or five spaces. Of the five elements, two are wide and three are narrow. The bar code is formed by interleaving characters formed with all spaces into characters formed with all bars. For more information, refer to an Interleaved 2 of 5 bar code specification.

Print Ratios Supported: 2.0 to 3.0.

^FD (Field Data) Limitations: 100+ characters. Actual amount of data depends on ^BY ratio and width (length if rotated) of label.

Figure 5.3 shows an example of the Interleaved 2 of 5 bar code and the instructions used to print it. Table 5.4 shows all of the characters associated with this code.

By definition, the total number of digits in an Interleaved code **MUST** be even. The printer automatically adds a leading zero if an odd number of digits is received.

The Interleaved 2 of 5 bar code uses the Mod 10 check digit scheme for error checking. (See Appendix B)



Figure 5.3 Interleaved 2 of 5 Bar Code

Characters	
0	1
2	3
4	5
6	7
8	9
Start	Stop (internal)

Table 5.4 Interleaved 2 of 5 Characters

BAR CODES

The format for the **^B2** instruction is:

^B2a,b,f,g,e

where

- ^B2** = Interleaved 2 of 5 bar code
- a** = Field Position
Default value: Current **^FW** setting
Other values:
 - R= Rotated (90 Degrees Clockwise)
 - I = Inverted (180 Degrees)
 - B= Bottom Up (270 Degrees - Read from bottom up)
- b** = Bar Code Height
Default value: Value set by **^BY**
Other values: 1 dot to 9999 dots
- f** = Print Interpretation Line
Default value: Y=Yes
Other value: N=No
- g** = Print Interpretation Line Above Code
Default value: N=No
Other value: Y=Yes
- e** = Calculate and print Mod 10 Check Digit
Default value: N = No
Other value: Y = Yes

Bar Codes

Industrial 2 of 5

^BI

^BI (Industrial 2 of 5) bar code instruction is a discrete, self-checking continuous numeric symbology. Industrial 2 of 5 Bar Code has been in use the longest of the 2 of 5 family of bar codes. Of that family, the Standard 2 of 5 and Interleaved 2 of 5 bar codes are also available in ZPL II.

In Industrial 2 of 5, all of the information is contained in the bars. Two bar widths are employed in this code, the wide bar being three times the width of the narrow bar.

Print Ratios Supported: 2.0 to 3.0.

^FD (Field Data) Limitations: 100+ characters. Actual amount of data depends on ^BY ratio and width (length if rotated) of label.

Figure 5.4 shows an example of the Industrial 2 of 5 bar code and the instructions used to print it. Table 5.5 shows all of the characters associated with this code.



Figure 5.4 Industrial 2 of 5 Bar Code

Characters	
0	1
2	3
4	5
6	7
8	9
Start (internal)	
Stop (internal)	

Table 5.5 Industrial 2 of 5 Characters

BAR CODES

The format for the **^BI** instruction is:

^BIa,b,f,g

where

- ^BI** = Industrial 2 of 5 bar code
- a** = Field Position
Default value: Current **^FW** setting
Other values:
 - R= Rotated (90 Degrees Clockwise)
 - I = Inverted (180 Degrees)
 - B= Bottom Up (270 Degrees - Read from bottom up)
- b** = Bar Code Height
Default value: Value set by **^BY**
Other values: 1 dot to 9999 dots
- f** = Print Interpretation Line
Default value: Y=Yes
Other value: N=No
- g** = Print Interpretation Line Above Code
Default value: N=No
Other value: Y=Yes

Bar Codes

Standard 2 of 5

^BJ

The **^BJ** (Standard 2 of 5) bar code instruction is a discrete, self-checking continuous numeric symbology.

In Standard 2 of 5, all of the information is contained in the bars. Two bar widths are employed in this code, the wide bar being three times the width of the narrow bar.

Print Ratios Supported: 2.0 to 3.0.

^FD (Field Data) Limitations: 100+ characters. Actual amount of data depends on ^BY ratio and width (length if rotated) of label.

Figure 5.5 shows an example of the Standard 2 of 5 bar code and the instructions used to print it. Table 5.6 shows all of the characters associated with this code.



Figure 5.5 Standard 2 of 5 Bar Code

Characters	
0	1
2	3
4	5
6	7
8	9
Start (automatic)	
Stop (automatic)	

Table 5.6 Standard 2 of 5 Characters

BAR CODES

The format for the **^BJ** instruction is:

^BJa,b,f,g

where

- ^BJ** = Standard 2 of 5 bar code
- a** = Field Position
Default value: Current **^FW** setting
Other values:
 - R= Rotated (90 Degrees Clockwise)
 - I = Inverted (180 Degrees)
 - B= Bottom Up (270 Degrees - Read from bottom up)
- b** = Bar Code Height
Default value: Value set by **^BY**
Other values: 1 dot to 9999 dots
- f** = Print Interpretation Line
Default value: Y=Yes
Other value: N=No
- g** = Print Interpretation Line Above Code
Default value: N=No
Other value: Y=Yes

Bar Codes

Codabar Bar Code

^BK

The **^BK** (ANSI Codabar) bar code instruction is currently used in a variety of information processing applications such as libraries, the medical industry, and overnight package delivery companies. This bar code is also known as USD-4 code, NW-7 and 2 of 7 code. It was originally developed for retail price-labeling use.

Each character in this code is composed of seven elements: four bars and three spaces. Codabar bar codes use two character sets:

- numeric characters
- control, start/stop characters

Print Ratios Supported: 2.0:1 to 3.0:1.

^FD (Field Data) Limitations: 100+ characters. Actual amount of data depends on ^BY ratio and width (length if rotated) of label.

Figure 5.6 shows an example of the ANSI Codabar bar code and the instructions used to print it. Table 5.7 shows all of the characters associated with this code.



Figure 5.6 ANSI Codabar Bar Code

Numeric Characters	
0	1
2	3
4	5
6	7
8	9
Control Characters	
-	\$
:	/
.	+
Start/Stop Characters	
A	T
B	N
C	*
D	E

Table 5.7 ANSI Codabar Characters

BAR CODES

The format for the **^BK** instruction is:

^BK*a,e,b,f,g,k,l*

where

- ^BK** = ANSI Codabar bar code
- a** = Field Position
Default value: Current **^FW** setting
Other values:
 - R= Rotated (90 Degrees Clockwise)
 - I = Inverted (180 Degrees)
 - B= Bottom Up (270 Degrees - Read from bottom up)
- e** = Check Digit (not implemented)
Default value: N = No
Other value: Y = Yes
- b** = Bar Code Height
Default value: Value set by **^BY**.
Other values: 1 dot to 9999 dots
- f** = Print Interpretation Line
Default value: Y=Yes
Other value: N=No
- g** = Print Interpretation Line Above Code
Default value: N=No
Other value: Y=Yes
- k** = Start Character
Default value: A
Other values: B,C,D,*,N,E or T
- l** = Stop Character
Default value: A
Other values: B,C,D,*,N,E or T

Bar Codes

The *k* and *l* parameters designate which Start and Stop characters will be used.

MSI Bar Code

^BM

The **^BM** (MSI) bar code is a pulse-width modulated, continuous non-self checking symbology. It is a variant of the Plessey bar code.

Each character in the MSI bar code is composed of eight elements: four bars and four adjacent spaces .

Print Ratios Supported: 2.0:1 to 3.0:1.

^FD (Field Data) Limitations: 1 - 14 digits when parameter 'e' is B, C or D, 1 - 13 digits when parameter 'e' is A, plus quiet zone.

Figure 5.7 shows an example of the MSI bar code and the instructions used to print it. Table 5.8 shows all of the characters associated with this code.



Figure 5.7 MSI Bar Code

Characters
0
1
2
3
4
5
6
7
8
9

Table 5.8 MSI Characters

BAR CODES

The format for the **^BM** instruction is:

^BMa,e,b,f,g,h

where:

- ^BM** = MSI bar code
- a** = Field Position
Default value: Current **^FW** setting
Other values:
 - R= Rotated (90 Degrees Clockwise)
 - I = Inverted (180 Degrees)
 - B= Bottom Up (270 Degrees - Read from bottom up)
- e** = Check Digit Selection
Default value: B = 1 Mod 10
Other values:
 - A= No Check Digits
 - C= 2 Mod 10
 - D = 1 Mod 10 and 1 Mod 11
- b** = Bar Code Height
Default value: Value set by **^BY**
Other values: 1 dot to 9999 dots
- f** = Print Interpretation Line
Default value: Y=Yes
Other value: N=No
- g** = Print Interpretation Line Above Code
Default value: N=No
Other value: Y=Yes
- h** = Print Check Digit in Interpretation Line
Default value: N=No
Other value: Y=Yes

Plessey Bar Code

^BP

The **^BP** (Plessey) bar code is a pulse-width modulated, continuous non-self checking symbology.

Each character in the Plessey bar code is composed of eight elements: four bars and four adjacent spaces.

Print Ratios Supported: 2.0:1 to 3.0:1.

^FD (Field Data) Limitations: 100+ characters. Actual amount of data depends on **^BY** ratio and width (length if rotated) of label.

Figure 5.8 shows an example of the Plessey bar code and the instructions used to print it. Table 5.9 shows all of the characters associated with this code.



Figure 5.8 Plessey Bar Code

<u>Characters</u>	
0	8
1	9
2	A
3	B
4	C
5	D
6	E
7	F

Table 5.9 Plessey Characters

BAR CODES

The format for the **^BP** instruction is:

^BPa,e,b,f,g

where:

- ^BP** = Plessey bar code
- a** = Field Position
Default value: Current **^FW** setting
Other values:
 - R= Rotated (90 Degrees Clockwise)
 - I = Inverted (180 Degrees)
 - B= Bottom Up (270 Degrees - Read from bottom up)
- e** = Print Check Digit (CRC8 2-digits)
Default value: N =No
Other value: Y= Yes
- b** = Bar Code Height
Default value: Value set by **^BY**
Other values: 1 dot to 9999 dots
- f** = Print Interpretation Line
Default value: Y=Yes
Other value: N=No
- g** = Print Interpretation Line Above Code
Default value: N=No
Other value: Y=Yes

POSTNET Bar Code

^BZ

The **^BZ** (POSTNET) bar code is used to automate the handling of mail. POSTNET uses a series of 5 bars, 2 tall and 3 short, to represent the digits 0 through 9.

Print Ratios Supported: Fixed Ratio.

^FD (Field Data) Limitations: 100+ characters. Actual amount of data depends on ^BY ratio and width (length if rotated) of label.

Figure 5.9 shows an example of the POSTNET bar code and the instructions used to print it. Table 5.10 shows all of the characters associated with this code.

Note: If **^CV** (Code Validation) is active, The length of the data field must be 5, 9 or 11 digits. A space or '-' is allowed if it is the sixth digit

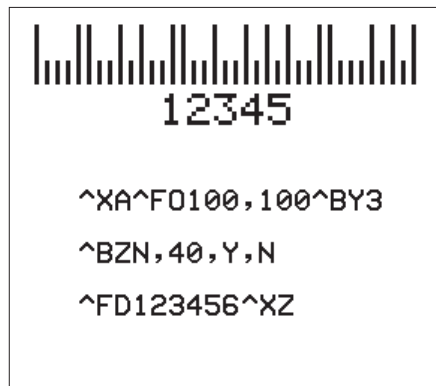

Figure 5.9 POSTNET Bar Code

Characters	
0	1
2	3
4	5
6	7
8	9

Table 5.10 POSTNET Characters

BAR CODES

The format for the **^BZ** instruction is:

^BZa,b,f,g

where:

- ^BZ** = POSTNET bar code
- a** = Field Position
Default value: Current **^FW** setting
Other values:
 - R= Rotated (90 Degrees Clockwise)
 - I = Inverted (180 Degrees)
 - B= Bottom Up (270 Degrees - Read from bottom up)
- b** = Bar Code Height
Default value: Value set by **^BY**
Other values: 1 dot to 9999 dots
- f** = Print Interpretation Line
Default value: N=No
Other value: Y=Yes
- g** = Print Interpretation Line Above Code
Default value: N=No
Other value: Y=Yes

Retail Labeling Bar Codes

EAN-8 Bar Code

^B8

The **^B8** (EAN-8) bar code instruction is the shortened version of the EAN-13 bar code. See EAN-13 (Page 5-28) for more information about EAN Bar Codes. EAN is an acronym for European Article Numbering.

Each character in EAN-8 Bar Code is composed of four elements; two bars, two spaces.

Print Ratios Supported: Fixed Ratio.

^FD (Field Data) Limitations: Exactly 7 characters. ZPL II automatically pads or truncates on the left with 0's to achieve required number of characters.

Figure 5.10 shows an example of the EAN-8 bar code and the instructions used to print it. Table 5.11 shows all of the characters associated with this code.

Note: JAN-8 (Japanese Article Numbering) system is a special application of EAN-8. In this case, the first two “non-zero” digits sent to the printer will always be 49.



Figure 5.10 EAN-8 Bar Code

Characters	
0	1
2	3
4	5
6	7
8	9

Table 5.11 EAN-8 Characters

BAR CODES

The format for the **^B8** instruction is:

^B8a,b,f,g

where

- ^B8** = EAN-8 bar code
- a** = Field Position
Default value: Current **^FW** setting
Other values:
 - R= Rotated (90 Degrees Clockwise)
 - I = Inverted (180 Degrees)
 - B = Bottom Up (270 Degrees - Read from bottom up)
- b** = Bar Code Height
Default value: Value set by **^BY**
Other values: 1 dot to 9999 dots
- f** = Print Interpretation Line
Default value: Y=Yes
Other value: N=No
- g** = Print Interpretation Line Above Code
Default value: N=No
Other value: Y=Yes

UPC-E Bar Code

^B9

The **^B9** (UPC-E) bar code instruction is a variation of the UPC symbology used for number system 0. UPC is an acronym for Universal Product Code. It is a shortened version of the UPC-A bar code in which zeros are suppressed, resulting in codes that require less printing space. It is used for labeling small items.

Note: When using the zero suppressed versions of UPC, the user **MUST** enter the full ten character sequence. ZPL II will then calculate and print the shortened version.

Each character in a UPC-E bar code is composed of four elements; two bars, two spaces.

Print Ratios Supported: Fixed Ratio.

^FD (Field Data) Limitations: Exactly 10 characters. Requires a 5-digit manufacturers code and a 5-digit product code.

Figure 5.11 shows an example of the UPC-E bar code and the instructions used to print it. Table 5.12 shows all of the characters associated with this code.

For more information, refer to a UPC-E Bar Code Specification.



Figure 5.11 UPC-E Bar Code

Characters	
0	1
2	3
4	5
6	7
8	9

Table 5.12 UPC-E Characters

The format for the **^B9** instruction is:

^B9a,b,f,g,e

where

- ^B9** = UPC-E bar code
- a** = Field Position
Default value: Current **^FW** setting
Other values:
R = Rotated (90 Degrees Clockwise)
I = Inverted (180 Degrees)
B = Bottom Up (270 Degrees - Read from bottom up)
- b** = Bar Code Height
Default value: Value set by **^BY**
Other values: 1 dot to 9999 dots
- f** = Print Interpretation Line
Default value: Y=Yes
Other value: N=No
- g** = Print Interpretation Line Above Code
Default value: N=No
Other value: Y=Yes
- e** = Print Check Digit
Default value: Y=Yes,
Other value: N=No

The Four Rules for Proper Product Numbers

1. If the last 3 digits in the Manufacturer's number are 000, 100 or 200, valid Product Code numbers are 00000 - 00999.
2. If the last 3 digits in the Manufacturers number are 300, 400, 500, 600, 700, 800 or 900, valid Product Code numbers are 00000 - 00099.
3. If the last 2 digits in the Manufacturers number are 10, 20, 30, 40, 50, 60, 70, 80 or 90, valid Product Code numbers are 00000 - 00009.
4. If the Manufacturer's number does not end in zero (0), valid Product Code numbers are 00005 - 00009

EAN-13 Bar Code

^BE

The **^BE** (EAN-13) bar code instruction is similar to the UPC-A bar code. It is widely used throughout Europe and Japan in the retail marketplace.

The EAN-13 bar code has 12 data characters, one more data character than the UPC-A code. An EAN-13 symbol contains the same number of bars as the UPC-A but encodes a 13th digit into a parity pattern of the left-hand six digits. This 13th digit, in combination with the 12th digit, represents a country code.

Print Ratios Supported: Fixed Ratio.

***^FD** (Field Data) Limitations: Exactly 12 characters. ZPL II automatically truncates or pads on the left with 0's to achieve required number of characters.*

Figure 5.12 shows an example of the EAN-13 bar code and the instructions used to print it. Table 5.13 shows all of the characters associated with this code.

The EAN-13 bar code uses the Mod 10 check digit scheme for error checking. (See Appendix B).

Note: JAN-13 (Japanese Article Numbering system) is a special application of EAN-13. The first two data values entered must be "49."



Figure 5.12 EAN-13 Bar Code

Characters	
0	1
2	3
4	5
6	7
8	9

Table 5.13 UPC/EAN Two-Digit Character Set

BAR CODES

The format for the **^BE** instruction is:

^BEa,b,f,g

where

- ^BE** = EAN-13 bar code
- a** = Field Position
Default value: N=Normal or current **^FW**
Other values:
 - R= Rotated (90 Degrees Clockwise)
 - I = Inverted (180 Degrees)
 - B= Bottom Up (270 Degrees - Read from bottom up)
- b** = Bar Code Height
Default value: Value set by **^BY**
Other values: 1 dot to 9999 dots
- f** = Print Interpretation Line
Default value: Y=Yes
Other value: N=No
- g** = Print Interpretation Line Above Code
Default value: N=No
Other value: Y=Yes

Bar Codes

UPC/EAN Extensions

^BS

The **^BS** (UPC/EAN extensions) instruction is the 2- and 5-digit add-on used primarily by publishers to create bar codes for ISBN's (International Standard Book Numbers, issued by R.R. Bowker). These extensions are handled as separate bar codes.

Although compatible with the UPC symbol, these extensions cannot be mistaken for a UPC symbol or for part of the UPC symbol by scanners designed to read only standard UPC symbols. This is because the UPC/EAN extension has only one guard pattern (on the left, encoded 1011) and its characters are separated by delineator characters.

Print Ratios Supported: Fixed Ratio.

^FD (Field Data) Limitations: Exactly 2 or 5 characters. ZPL II automatically truncates or pads on the left with 0's to achieve required number of characters.

Figure 5.13 shows an example of the UPC/EAN two-digit extension and the instructions used to print it. Table 5.14 shows all of the characters associated with this code.

Figure 5.14 on Page 5-31 shows an example of the UPC/EAN two and five-digit extension and the instructions used to print it. Table 5.15 on Page 5-31 shows all of the characters associated with this code.

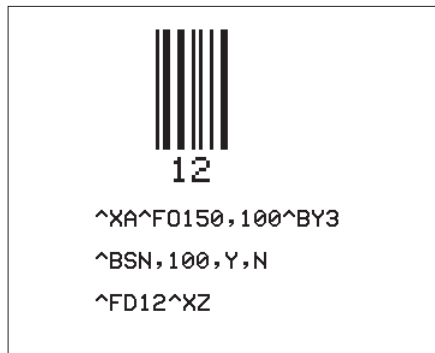

Figure 5.13 UPC/EAN Two-Digit Extension

Characters	
0	1
2	3
4	5
6	7
8	9

Table 5.14 UPC/EAN Two-Digit Character Set



Figure 5.14 UPC/EAN Five-Digit Extension

Characters	
0	1
2	3
4	5
6	7
8	9

Table 5.15 UPC/EAN Two and Five-Digit Character Set

The format for the **^BS** instruction is:

^BSa,b,f,g

where

- ^BS** = UPC/EAN extension
- a** = Field Position
Default value: Current **^FW** setting
Other values:
 R= Rotated (90 Degrees Clockwise)
 I= Inverted (180 Degrees)
 B= Bottom Up (270 Degrees - Read from bottom up)
- b** = Bar Code Height
Default value: Value set by **^BY**
Other values: 1 dot to 9999 dots
- f** = Print Interpretation Line
Default value: Y=Yes
Other value: N=No
- g** = Print Interpretation Line Above Code
Default value: Y=Yes
Other value: N=No

Bar Codes

BAR CODES

Care should be taken in positioning the UPC/EAN extension with respect to the UPC-A (or UPC-E) code to insure the resultant composite code is within the UPC specification.

For UPC codes, with a module width of 2 (default), the Field Origin offsets for the extension are as follows:

UPC-A

	Supplement Origin <u>X - Offset</u>	Adjustment <u>Y - Offset</u>
Normal	209 dots	21 dots
Rotated	0	209 dots

UPC-E

	Supplement Origin <u>X - Offset</u>	Adjustment <u>Y - Offset</u>
Normal	122 dots	21 dots
Rotated	0	122 dots

Additionally, the bar code height for the extension should be 27 dots (0.135 inches) shorter than that of the Primary code. A Primary UPC code height of 183 dots (0.900 inches) would require a extension height of 155 dots (0.765).

Figure 5.15 shows an example of how to create a normal UPC-A code for the value 7000002198 with an extension equal to 04414.



Figure 5.15 UPC-A Bar Code with an Extension

UPC-A Bar Code

^BU

The **^BU** (UPC-A) bar code instruction is a fixed length, numeric, continuous symbology. It is primarily used in the retail industry for labeling packages. The UPC-A bar code has 11 data characters. An 8 dot/mm printhead can produce UPC/EAN symbologies at a magnification factor of 77%.

For more information, refer to a UPC-A Bar Code Specification.

Print Ratios Supported: Fixed Ratio.

^FD (Field Data) Limitations: Exactly 11 characters. ZPL II automatically truncates or pads on the left with 0's to achieve required number of characters.

Figure 5.16 shows an example of the UPC-A bar code and the instructions used to print it. Table 5.16 shows all of the characters associated with this code.

The UPC-A bar code uses the Mod 10 check digit scheme for error checking. (See Appendix B).



Figure 5.16 UPC-A Bar Code

Characters	
0	1
2	3
4	5
6	7
8	9

Table 5.16 UPC-A Character Set

BAR CODES

The format for the **^BU** instruction is:

^BUa,b,f,g,e

where

- ^BU** = UPC-A bar code
- a** = Field Position
Default value: Current **^FW** setting
Other values:
 - R= Rotated (90 Degrees Clockwise)
 - I = Inverted (180 Degrees)
 - B= Bottom Up (270 Degrees - Read from bottom up)
- b** = Bar Code Height
Default value: Value set by **^BY**
Other values: 1 dot to 9999 dots
- f** = Print Interpretation Line
Default value: Y=Yes
Other value: N=No
- g** = Print Interpretation Line Above Code
Default value: N=No
Other value: Y=Yes
- e** = Print Check Digit
Default value: Y=Yes,
Other value: N=No

Bar Codes

The font style of the interpretation line depends on the modulus (width of narrow bar) selected in **^BY**. A modulus of 2 dots and greater will print with an OCR-B interpretation line; a modulus of 1 dot will print font A.

Alphanumeric Bar Codes

Code 39 Bar Code

^B3

The **^B3** (Code 39) bar code instruction is the standard for many industries, including adoption by the U.S. Department of Defense (DOD) and is one of three symbologies identified in the American National Standards Institute (ANSI) standard MH10.8M-1983. This code is also known as USD-3 code and 3 of 9 code.

Each character in Code 39 bar code is composed of nine elements; five bars, four spaces, and intercharacter gap. Three of the nine elements are wide; six elements are narrow.

Print Ratios Supported: 2.0:1 to 3.0:1.

^FD (Field Data) Limitations: 100+ characters. Actual amount of data depends on ^BY ratio and width (length if rotated) of label..

Figure 5.17 shows an example of the Code 39 bar code and the instructions used to print it. Table 5.17 shows all of the characters associated with this code.

Code 39 is also capable of encoding the full 128 ASCII Character Set. See Tables 5-22(A) and (B) on pages 5-48 and 5-49 respectively.



Figure 5.17 Code 39 Bar Code

Characters				
1	A	K	U	-
2	B	L	V	.
3	C	M	W	\$
4	D	N	X	/
5	E	O	Y	+
6	F	P	7	%
7	G	Q		
8	H	R		
9	I	S		
0	J	T	Space	

Table 5.17 Code 39 Character Set

The format for the **^B3** instruction is:

^B3a,e,b,f,g

where

- ^B3** = Code 39 bar code
- a** = Field Position
Default value: Current **^FW** setting
Other values:
 - R = Rotated (90 Degrees Clockwise)
 - I = Inverted (180 Degrees)
 - B = Bottom Up (270 Degrees - Read from bottom up)
- e** = Mod-43 Check Digit
Default value: N=No
Other value: Y= Yes
- b** = Bar Code Height
Default value: Value set by **^BY**
Other values: 1 dot to 9999 dots
- f** = Print Interpretation Line
Default value: Y=Yes
Other value: N=No
- g** = Print Interpretation Line Above Code
Default value: N=No
Other value: Y=Yes

For the Code 39 bar code, the Start and Stop Character (an asterisk) is automatically generated.

Note: Information on the MOD-43 check digit can be found in Appendix C.

Code 93 Bar Code

^BA

The **^BA** (Code 93) bar code instruction is a variable length, continuous symbology. It is used in many of the same applications as the Code 39 bar code. It uses the full 128 character ASCII Code. ZPL II, however, does not support ASCII control codes or escape sequences, so it uses the substitute characters shown below. This code is also known as USS-93.

<u>Control Code</u>	<u>ZPL II Substitute</u>
Ctrl \$	&
Ctrl %	‘
Ctrl /	(
Ctrl +)

Each character in Code 93 Bar Code is composed of six elements; three bars, three spaces. Although invoked differently, the human-readable interpretation line will print as though the control code had been used.

Note: Control codes are used in pairs. Refer to a Code 93 specification for further details.

Print Ratios Supported: Fixed Ratio.

^FD (Field Data) Limitations: 100+ characters. Actual amount of data depends on ^BY ratio and width (length if rotated) of label.

Figure 5.18 shows an example of the Code 93 bar code and the instructions used to print it. Table 5.18 shows all of the characters associated with this code.



0123ABCO

```
^XA^F0100,75^BY3
^BAN,100,Y,N,N
^FD12345ABCDE^XZ
```

Characters

1	2	3	4	5	6	7	8	9	0
A	B	C	D	E	F	G	H	I	
J	K	L	M	N	O	P	Q	R	
S	T	U	V	W	X	Y	Z		
-	.	\$	/	+	%	&	'	()
Space									

Denotes a internal start/stop character that must precede and follow every bar code message.

Figure 5.18 Code 39 Bar Code Table 5.18 Code 93 Character Set

BAR CODES

The format for the **^BA** instruction is:

^BAa,b,f,g,e

where

- ^BA** = Code 93 bar code
- a** = Field Position
Default value: Current **^FW** setting
Other values:
 - R= Rotated (90 Degrees Clockwise)
 - I= .Inverted (180 Degrees)
 - B= Bottom Up (270 Degrees - Read from bottom up)
- b** = Bar Code Height
Default value: Value set by **^BY**
Other values: 1 dot to 9999 dots
- f** = Print Interpretation Line
Default value: Y=Yes
Other value: N=No
- g** = Print Interpretation Line Above Code
Default value: N=No
Other value: Y=Yes
- e** = Print check digit
Default value: N=No
Other value: Y=Yes

Code 93 is also capable of encoding the full 128 ASCII Character Set. See Tables 5-23(A) and (B) on pages 5-50 and 5-51 respectively.

Code 128 Bar Code (Subsets A, B, and C)

^BC

The **^BC** (Code 128) bar code instruction is a high density, variable length, continuous alphanumeric symbology. It was designed for complex encoded product identification. This is also known as a USD-6 bar code.

Code 128 has three subsets of characters. There are 106 printing (encoded) characters in each set. Therefore, each character can have up to three different meanings, depending on the character subset being used.

Each Code 128 character consists of six elements. Three bars and three spaces.

Print Ratios Supported: Fixed Ratio.

***^FD** (Field Data) Limitations: 100+ characters. Actual amount of data depends on **^BY** ratio and width (length if rotated) of label.*

Figure 5.19 shows a typical example of the Code 128 bar code and the instructions used to print it. Table 5.19 on Page 5-40 shows all of the characters associated with this code.



Figure 5.19 Code 128 Bar Code

BAR CODES

The format for the **^BC** instruction is:

^BCa,b,f,g,e,m

where

- ^BC** = Code 128 bar code
- a** = Field Position
Default value: Current **^FW** setting
Other values:
 - R= Rotated (90 Degrees Clockwise)
 - I= Inverted (180 Degrees)
 - B= Bottom Up (270 Degrees - Read from bottom up)
- b** = Bar Code Height
Default value: Value set by **^BY**
Other values: 1 dot to 9999 dots
- f** = Print Interpretation Line
Default value: Y=Yes
Other value: N=No
Note: Intrepretation line can be printed in any available font by placing the instruction for the font directly before the bar code instruction.
- g** = Print Interpretation Line Above Code
Default value: N=No
Other value: Y=Yes
Note: Default changes to Yes in UCC Case Code
- e** = UCC check digit
Default value: N=No
Other value: Y=Yes
- m** = Mode
Default value: N = No mode selected
Other value: U = UCC Case Mode
(**^FD** or **^SN** statement must contain 19 numeric digits (it can also contain valid non-numeric characters). Subset C using FNC1 values is automatically selected.

BAR CODES

Value	Code A	Code B	Code C	Value	Code A	Code B	Code C
0	SP	SP	00	53	U	U	53
1	!	!	01	54	V	V	54
2	"	"	02	55	W	W	55
3	#	#	03	56	X	X	56
4	\$	\$	04	57	Y	Y	57
5	%	%	05	58	Z	Z	58
6	&	&	06	59	[[59
7	'	'	07	60	\	\	60
8	((08	61]]	61
9))	09	62			62
10	*	*	10	63	-	-	63
11	++	++	11	64	NUL	.	64
12	,	,	12	65	SOH	a	65
13	-	-	13	66	STX	b	66
14	.	.	14	67	ETX	c	67
15	/	/	15	68	EOT	d	68
16	0	0	16	69	ENQ	e	69
17	1	1	17	70	ACK	f	70
18	2	2	18	71	BEL	g	71
19	3	3	19	72	BS	h	72
20	4	4	20	73	HT	i	73
21	5	5	21	74	LF	j	74
22	6	6	22	75	VT	k	75
23	7	7	23	76	FF	l	76
24	8	8	24	77	CR	m	77
25	9	9	25	78	SO	n	78
26	:	:	26	79	SI	o	79
27	;	;	27	80	DLE	p	80
28	<	<	28	81	DC1	q	81
29	=	=	29	82	DC2	r	82
30	>	>	30	83	DC3	s	83
31	?	?	31	84	DC4	t	84
32	@	@	32	85	NAK	u	85
33	A	A	33	86	SYN	v	86
34	B	B	34	87	ETB	w	87
35	C	C	35	88	CAN	x	88
36	D	D	36	89	EM	y	89
37	E	E	37	90	SUB	z	90
38	F	F	38	91	ESC	{	91
39	G	G	39	92	FS		92
40	H	H	40	93	GS	}	93
41	I	I	41	94	RS	~	94
42	J	J	42	95	US	DEL	95
43	K	K	43	96	FNC3	FNC3	96
44	L	L	44	97	FNC2	FNC2	97
45	M	M	45	98	SHIFT	SHIFT	98
46	N	N	46	99	Code C	Code C	99
47	O	O	47	100	Code B	FNC4	Code B
48	P	P	48	101	FNC4	Code A	Code A
49	Q	Q	49	102	FNC1	FNC1	FNC1
50	R	R	50	103		START (Code A)	
51	S	S	51	104		START (Code B)	
52	T	T	52	105		START (Code C)	

Table 5.19 Code 128 Character Sets

Special Conditions if UCC Case Mode is Selected

1. Excess digits (above 19) in **^FD** or **^SN** will be eliminated.
2. Below 19 digits in **^FD** or **^SN** adds zeros to right to bring count to 19. *(This produces an invalid interpretation line.)*

Code 128 Subsets

The three Code 128 character subsets are referred to as Subset A, Subset B, and Subset C. A subset may be selected in one of two ways.

1. A special Invocation Code can be included in the field data (**^FD**) string associated with that bar code.
2. Place the desired Start Code at the beginning of the field data. If no Start Code is entered, Subset B will be used.

To change subsets within a bar code, place the appropriate Invocation Code at the appropriate points within the field data string. The new subset will stay in effect until changed with appropriate Invocation Code. (For example, in Subset C, a “>7” in the field data changes the Subset to A.) Table 5.20 shows the Code 128 Invocation Codes and Start Characters for the three subsets.

Invocation Code	Decimal Value	Subset A Character	Subset B Character	Subset C Character
><	62			
>0	30	>	>	
>=	94		~	
>1	95	USQ	DEL	
>2	96	FNC 3	FNC 3	
>3	97	FNC 2	FNC 2	
>4	98	SHIFT	SHIFT	
>5	99	CODE C	CODE C	
>6	100	CODE B	FNC 4	CODE B
>7	101	FNC 4	CODE A	CODE A
>8	102	FNC 1	FNC 1	FNC 1
Start Characters				
>9	103	Start Code A	(Numeric Pairs give Alpha/Numerics)	
>:	104	Start Code B	(Normal Alpha/Numeric)	
>;	105	Start Code C	(All Numeric 00 - 99)	

Table 5.20 Code 128 Invocation Characters

Bar Codes

Example of Code 128 - Subset B

Since Code 128 subset ‘B’ is the most commonly used subset, ZPL II defaults to subset ‘B’ if no start character is specified in the data string. This is demonstrated in Figures 5.20 and 5.21.

The bar codes in Figures 5.20 and 5.21 are identical.



Figure 5.20 Subset B - No Start Character

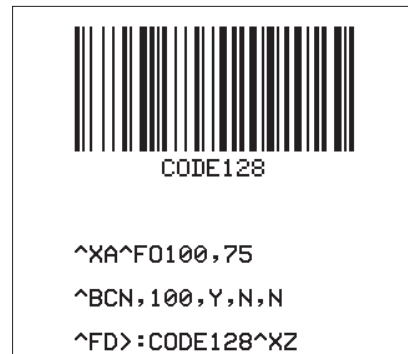

Figure 5.21 Subset B - With Start Character

The first two instructions (**^XA^FO100,75**) start the label format and sets the field origin (from the upper-left corner) at which the bar code field begins to 100 dots across the x axis and 75 dots down the y axis.

The third instruction (**^BCN,150,Y,N,N**) calls for a Code 128 style bar code to be printed with no rotation and a height of 150 dots.

Instruction four (**^FDCODE128** in Figure 5.20) and (**^FD>:CODE128** in Figure 5.21) specify the content of the bar code.

Instructions 5 (**^XZ**) indicates the end of the print field and the end of the label format.

Note: The **^FD** instruction for Figure 5.20 does not specify any subset so the ‘B’ subset is used. In Figure 5.21, the **^FD** instruction specifically calls subset ‘B.’ Although ZPL II defaults to Code B, it is very good practice to include the “invocation characters” in the instruction.

BAR CODES

Code 128 - subset B is programmed directly as ASCII text, except for values greater than 94 decimal and a few special characters:

^ > ~

These characters must be programmed by using the invocation codes shown in Table 5.20 on Page 5-43.

Example of Code 128 - Subsets A and C

Code 128 subsets A and C are programmed as pairs of digits, 00-99, in the field data string. (Refer to the Code 128 characters chart in Table 5.19 on page 5-42).

In subset A, the pairs of digits will result in both numbers and alpha characters being printed; in subset C, they are printed as entered. Figure 5.24 is an example of Subset A. (The ">9" is the Start Code for Subset A.)

Note: Non-integers programmed as the first character of a digit pair (D2) are ignored. However, non-integers programmed as the second character of a digit pair (2D) invalidate the entire digit pair, and the pair is ignored. An extra, unpaired digit in the field data string just before a code shift is also ignored.

Figures 5.22 and 5.23 are examples of subset C. Notice that the bar codes in the figures are identical. In the program code for Figure 5.23 the D is ignored and the 2 is paired with the 4.



Figure 5.22 Subset C -
Normal Data



Figure 5.23 Subset C -
Ignored Alpha Character



Figure 5.24 Subset A

LOGMARS Bar Code

^BL

The **^BL** (LOGMARS) bar code instruction is a special application of Code 39 used by the Department of Defense (DOD). LOGMARS is an acronym for Logistics Applications of Automated Marking and Reading Symbols.

Print Ratios Supported: 2.0:1 to 3.0:1.

^FD (Field Data) Limitations: 100+ characters. Actual amount of data depends on ^BY ratio and width (length if rotated) of label.

Figure 5.25 shows an example of the Logmars bar code and the instructions used to print it. Table 5.21 shows all of the characters associated with this code.

For more information, refer to a LOGMARS bar code Specification.

Note: The LOGMARS bar code produces a “mandatory” check digit using MOD-43 calculations. For further information, refer to Appendix C.



Figure 5.25 LOGMARS Bar Code

Characters									
1	2	3	4	5	6	7	8	9	0
A	B	C	D	E	F	G	H	I	
J	K	L	M	N	O	P	Q	R	
S	T	U	V	W	X	Y	Z		
-	.	*	\$	/	+	%		Space	

Table 5.21 LOGMARS Character Set

BAR CODES

The format for the **^BL** instruction is:

^BLa,b,g

where

- ^BL** = LOGMARS bar code
- a** = Field Position
Default value: Current **^FW** setting
Other values:
 - R= Rotated (90 Degrees Clockwise)
 - I= Inverted (180 Degrees)
 - B= Bottom Up (270 Degrees - Read from bottom up)
- b** = Bar Code Height
Default value: Value set by **^BY**
Other values: 1 dot to 9999 dots
- g** = Print Interpretation Line Above Code
Default value: N=No
Other value: Y=Yes

Bar Codes

BAR CODES

Full ASCII Mode for Code 39

Code 39 can generate the full 128 ASCII character set using paired characters as shown in Tables 5-22(A) and (B).

ASCII	Code 39	ASCII	Code 39
NUL	%U	SP	Space
SOH	\$A	!	/A
STX	\$B	"	/B
ETX	\$C	#	/C
EOT	\$D	\$	/D
ENQ	\$E	%	/E
ACK	\$F	&	/F
BEL	\$G	'	/G
BS	\$H	(/H
HT	\$I)	/I
LF	\$J	*	/J
VT	\$K	++	/K
FF	\$L	,	/L
CR	\$M	-	-
SO	\$N	.	.
SI	\$O	/	/O
DLE	\$P	0	0
DC1	\$Q	1	1
DC2	\$R	2	2
DC3	\$S	3	3
DC4	\$T	4	4
NAK	\$U	5	5
SYN	\$V	6	6
ETB	\$W	7	7
CAN	\$X	8	8
EM	\$Y	9	9
SUB	\$Z	:	/Z
ESC	%A	;	%F
FS	%B	<	%G
FS	%C	=	%H
RS	%D	>	%I
US	%E	?	%J

Table 5.22 (A) Code 39 Full ASCII MODE

BAR CODES

ASCII	Code 39	ASCII	Code 39
@	%V	'	%W
A	A	a	+A
B	B	b	+B
C	C	c	+C
D	D	d	+D
E	E	e	+E
F	F	f	+F
G	G	g	+G
H	H	h	+H
I	I	i	+I
J	J	j	+J
K	K	k	+K
L	L	l	+L
M	M	m	+M
N	N	n	+M
O	O	o	+O
P	P	p	+P
Q	Q	q	+Q
R	R	r	+R
S	S	s	+S
T	T	t	+T
U	U	u	+U
V	V	v	+V
W	W	w	+W
X	X	x	+X
Y	Y	y	+Y
Z	Z	z	+Z
[%K	{	%P
\	%L		%Q
]	%M	}	%R
	%N	~	%S
	%O	DEL	%T, %X

Bar Codes

Table 5.22 (B) Code 39 Full ASCII MODE

BAR CODES

Full ASCII Mode for Code 93

Code 93 can generate the full 128 ASCII character set using paired characters as shown in Tables 5-23(A) and (B).

ASCII	Code 93	ASCII	Code 93
NUL	'U	SP	Space
SOH	&A	!	(A
STX	&B	"	(B
ETX	&C	#	(C
EOT	&D	\$	(D
ENQ	&E	%	(E
ACK	&F	&	(F
BEL	&G	'	(G
BS	&H	((H
HT	&I)	(I
LF	&J	*	(J
VT	&K	++	++
FF	&L	'	(L
CR	&M	-	-
SO	&N	.	.
SI	&O	/	/
DLE	&P	0	O
DC1	&Q	1	1
DC2	&R	2	2
DC3	&S	3	3
DC4	&T	4	4
NAK	&U	5	5
SYN	&V	6	6
ETB	&W	7	7
CAN	&X	8	8
EM	&Y	9	9
SUB	&Z	:	(Z
ESC	'A	;	'F
FS	'B	<	'G
FS	'C	=	'H
RS	'D	>	'I
US	'E	?	'J

Table 5.23 (A) Code 93 Full ASCII Mode

BAR CODES

ASCII	Code 93	ASCII	Code 93
@	'V	'	'W
A	A	a)A
B	B	b)B
C	C	c)C
D	D	d)D
E	E	e)E
F	F	f)F
G	G	g)G
H	H	h)H
I	I	i)I
J	J	j)J
K	K	k)K
L	L	l)L
M	M	m)M
N	N	n)N
O	O	o)O
P	P	p)P
Q	Q	q)Q
R	R	r)R
S	S	s)S
T	T	t)T
U	U	u)U
V	V	v)V
W	W	w)W
X	X	x)X
Y	Y	y)Y
Z	Z	z)Z
['K	{	'P
\	'L		'Q
]	'M	}	'R
	'N	~	'S
	'O	DEL	'T

Bar Codes

Table 5.23 (B) Code 93 Full ASCII Mode

Two-Dimensional Bar Codes

Code 49 Bar Code

^B4

The **^B4** (Code 49) bar code is a multi-row, continuous variable length symbology capable of encoding the full 128 ASCII character set. It is ideally suited to applications where large amounts of data are required in a small space.

(Currently offered as an Option on Zebra STRIPE Printers.)

The code consists of 2 to 8 rows. A row consists of a leading quiet zone, 4 symbol characters encoding 8 code characters, a stop pattern, and a trailing quiet zone. Rows are separated by a 1-module high separator bar. Each symbol character encodes two characters from a set of 49 code characters (See Table 5.24 on Page 54 for information on using the Code 49 character set). Rows can be scanned in any order.

Refer to the *Uniform Symbology Specification USS-49* for further information.

Print Ratio is Fixed

The illustration below shows an example of the Code 49 bar code and the instructions used to print it. The Table on Page 54 shows all of the characters associated with this code.

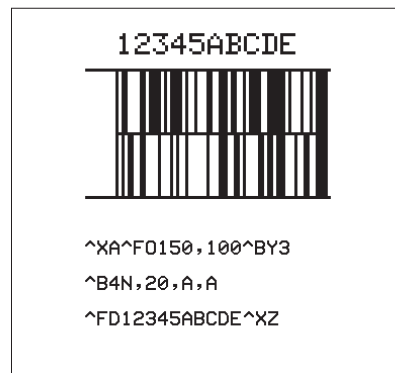

Figure 5.26 Code 49 Bar Code

The format for the **^B4** instruction is:

^B4a,b,f,m

where

- ^B4** = Code 49 bar code
- a** = Field Position
Default value: Current **^FW** value (**^FW** defaults to N = Normal at power-up)
Other values:
 R = Rotated (90 Degrees Clockwise)
 I = Inverted (180 Degrees)
 B = Bottom (270 Degrees - Read from bottom up)
- b** = Height Multiplier of Individual Rows
Defined: This number, multiplied by the module, equals the height of the individual rows in dots.
Default value: Value set by **^BY**
Other values: 1 to height of label.
Note: 1 is not a recommended value.
- f** = Print Interpretation Line
Default value: N = No line printed.
Other values:
 A = Print interpretation line above code.
 B = Print interpretation line below code.
Note: When the code is greater than 2 rows, expect interpretation line to extend well beyond the right edge of the code.
- m** = Starting Mode
Default value: A = Automatic Mode. Printer determines starting mode by analyzing field data.
Other values:
 0 = Regular Alphanumeric Mode
 1 = Multiple Read Alphanumeric
 2 = Regular Numeric Mode
 3 = Group Alphanumeric Mode
 4 = Regular Alphanumeric Shift 1
 5 = Regular Alphanumeric Shift 2

Bar Codes

BAR CODES

Field Data Set	Unshifted Character Set	Shift 1 Character Set	Shift 2 Character Set
0	0	.	.
1	1	ESC	;
2	2	FS	<
3	3	GS	=
4	4	RS	>
5	5	US	?
6	6	!	@
7	7	"	[
8	8	#	\
9	9	&]
A	A	SOH	a
B	B	STX	b
C	C	ETX	c
D	D	EOT	d
E	E	ENQ	e
F	F	ACK	f
G	G	BEL	g
H	H	BS	h
I	I	HT	i
J	J	LF	j
K	K	VT	k
L	L	FF	l
M	M	CR	m
N	N	SO	n
O	O	SI	o
P	P	DLE	p
Q	Q	DC1	q
R	R	DC2	r
S	S	DC3	s
T	T	DC4	t
U	U	NAK	u
V	V	SYN	v
W	W	ETB	w
X	X	CAN	x
Y	Y	EM	y
Z	Z	SUB	z
-	-	(-
.	.)	.
space	space	Null	DEL
\$	\$	*	{
/	/	,	
++	++	:	}
%	%	reserved	~
< (Shift 1)			
> (Shift 2)			
: (N.A.)			
; (N.A.)			
? (N.A.)			
= (Numeric Shift)			

Table 5.24 Code 49 Shift 1 & 2 Character Substitutions

Code 49 Field Data Character Set

The **^FD** Character Set sent to the printer when using Starting Modes 0 thru 5 is based on the Code 49 Internal Character Set. This is shown in the first column of Table 1. The characters : ; < = > and ? are special Code 49 control characters.

Valid field data must be supplied when using modes 0 thru 5. Shifted characters are sent as a two-character sequence of a “shift character” followed by a “character in the unshifted character set.” For example, to print a lower case ‘a,’ send a “Shift 2” followed by an ”A” (>A). If interpretation line printing is selected, a lower case ‘a’ would print in the interpretation line.

Note: Code 49 uses UPPERCASE Alpha characters only.

If an invalid sequence is detected, the code 49 formatter will stop interpreting field data and print a symbol with the data up to the invalid sequence. The following are examples of invalid sequences.

- Terminating numeric mode with any characters other than 0 thru 9 or a Numeric Space.
- Starting in Mode 4 (Regular Alphanumeric Shift 1) and the first field data character is not in the S1 set.
- Starting in Mode 5 (Regular Alphanumeric Shift 2) and the first field data character is not in the S2 set.
- Sending S1 followed by a character not in the S1 set.
- Sending S2 followed by a character not in the S2 set.
- Sending two S1 or S2 controls characters.

Advantages of Using the Code 49 Automatic Mode

Using the Automatic (Default) Mode completely eliminates the need for selecting the starting mode or manually performing character shifts. The Automatic Mode analyzes the incoming ASCII string, determines the proper mode, performs all character shifts and compacts the data for maximum density.

Note: Numeric mode will only be selected or shifted when 5 or more continuous digits are found. Numeric packaging provides no space advantage for numeric strings of less than 8 characters.

PDF417 Bar Code

^B7

The **^B7** (PDF417) bar code instruction is a two-dimensional multi-row, continuous, stacked symbology. This bar code is capable of encoding over 1000 bytes of data per label. It is ideally suited to applications where large amounts of information are required at the time the bar code is read.

(Currently offered as an Option on Zebra STRIPE Printers.)

The code consists of 3 to 90 stacked rows. Each row consists of start/stop patterns and symbol characters called “codewords.” A “codeword” consists of 4 bars and 4 spaces. The minimum number of “codewords” per row is 3.

Print Ratio is Fixed.

The illustration below shows an example of the PDF417 bar code. The instructions to create the bar code are shown below. The text used in the **^FD**—**^FS** statement is shown at the right of the bar code.

```

^XA^BY2,3
^FO10,10^B7N,5,5,,83,N
^FD(Text shown at right of bar code)^FS
^XZ
    
```

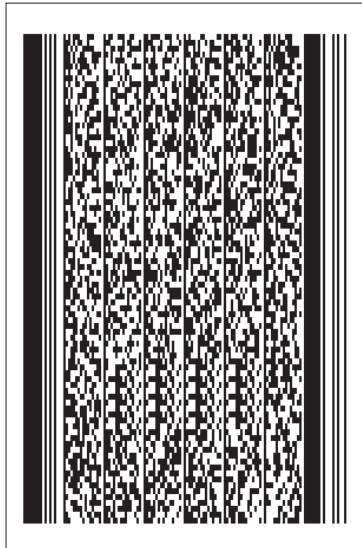

Zebra Technologies Corporation strives to be the expert supplier of innovative solutions to specialty demand labelling and ticketing problems of business and government. We will attract and retain the best people who will understand our customer's needs and provide them with systems, hardware, software, consumables and service offering the best value, high quality, and reliable performance, all delivered in a timely manner.

The format for the **^B7** instruction is:

^B7a,b,s,c,r,t

where

- ^B7** = PDF417 bar code
- a** = Field Position
Default value: Current **^FW** value (**^FW** defaults to N=Normal at power-up)
Other values:
 R = Rotated (90 Degrees Clockwise)
 I = Inverted (180 Degrees)
 B = Bottom Up (270 Degrees - Read from bottom up.)
- b** = Bar Code Height for Individual Rows
 (This number, multiplied by the module, equals the height of the individual rows in dots.)
Default value: Value set by **^BY**
Other values: 1 dot to height of label.
Note: 1 is not a recommended value.
- s** = Security Level. Determines the number of error detection and correction code words to be generated for the symbol. Default level provides only error detection (no correction). Increasing the security level adds increasing levels of error correction. (Increases symbol size.)
Default value: 0 = Error detection only
Other values: 1 to 8. Error detection plus correction.
- c** = Number of data columns to encode. User can specify number of codeword columns giving control over the width of the symbol.
Default value: 1:2 row/column aspect ratio.
Other values: 1 to 30

BAR CODES

- r** = Number of rows to encode. User can specify number of symbol rows giving control over the height of the symbol.
Default value: 1:2 row/column aspect ratio.
Other values: 3 to 90
Example: With no row or column values entered, 72 codewords would be encoded into a symbol of 6 columns and 12 rows. (Depending on codewords, aspect ratio will not always be exact.)
- t** = Truncate right row indicators and stop pattern.
Default value: N = No truncation. Print right row indicators and stop pattern.
Other value: Y = Yes perform truncation.

Notes:

- 1) If both columns and rows are specified, their product must be less than 928.
- 2) No symbol printed if columns x rows > 928.
- 3) No symbol printed if total codewords > columns x rows.
- 4) Serialization is not allowed with this bar code.
- 5) The truncation feature can be used in situations where label damage is not likely. The right row indicators and stop pattern will be reduced to a single module bar width. The difference between a non-truncated and a truncated bar code is shown below.

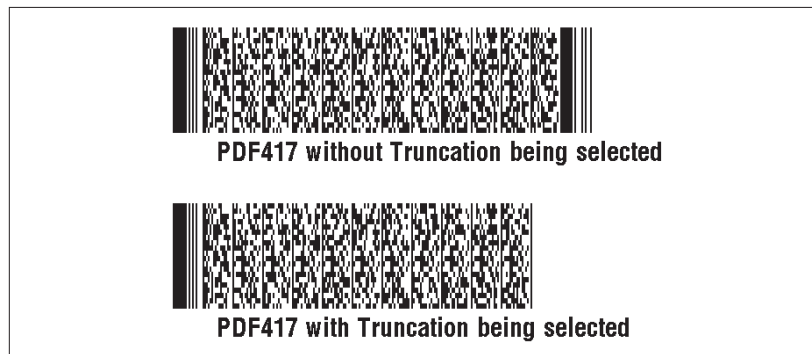

Special considerations for the ^BY instruction when using PDF417.

The parameters for the **^BY** i,j,b instruction when used with a **^B7** PDF417 code are as follows;

- i = Module width. (Default = 2) Limited to 10.
- j = Ratio (Default = 3) Fixed. Has no effect on PDF417.
- b= Height of bars. Overall symbol height.
PDF417 uses this as the overall symbol height only when the row height is not specified in the **^B7** 'b' parameter.

Special considerations for the ^FD character set when using PDF417.

The character set sent to the printer includes the full ASCII set except for those characters with special meaning to the printer.

CR/LF have become valid characters for all **^FD** statements. The following scheme will be used.

- “ \& ” = carriage return/line feed
- “ \(*)” = soft hyphen (word break with a dash)
- “ \\ ” = \ (See Item 1 below)
- (*) = Any alpha/numeric character.

Item 1: **^CI13** must be selected in order to print a \.

Item 2: If a soft hyphen is placed near the end of a line, the hyphen will be printed. If it is not placed near the end of the line, it will be ignored. (Ignored in **^B7** barcode.)

Bar Code Validation

^CV

The **^CV** (Code Validation) instruction acts as a switch to turn the code validation function ON and OFF. When this instruction is turned ON, all bar code data will be checked for the following error conditions:

- Character not in character set
- Check digit incorrect
- Data field too long (too many characters)
- Data field too short (too few characters)

When invalid data is detected, an error message and code will be printed in reverse image in place of the bar code. The message will read "INVALID - X" where "X" is one of the following error codes:

- C = Character not in character set
- E = Check digit incorrect
- L = Data field too long
- S = Data field too short

Once turned on, the **^CV** instruction will remain active from format to format until turned off by another **^CV** instruction or the printer is turned off. The instruction IS NOT permanently saved.

Note: If more than one error exists, the first error detected will be the one displayed.

The format for the **^CV** instruction is:

^CV_x

where:

- ^CV** = Bar Code Validation
- x** = Code Validation
Default value: N = No
Other values: Y = Yes

On the following page is an example of how the **^CV** instruction works. At the top of the page is a correctly printed bar code. It is followed by an example of each of the four error messages.

BAR CODES



^F0220,10^BEN,100,Y,N^FD9782345678908^FS

INVALID - C

^F0220,10^BEN,100,Y,N^FD97823456 890^FS

THE ^FD STATEMENT IN THE ZPL STRING HAS AN INVALID CHARACTER. THIS RESULTED IN THE "INVALID - C" MESSAGE BEING PRINTED IN PLACE OF THE BAR CODE.

INVALID - E

^F0220,10^BEN,100,Y,N^FD9782345678907^FS

THE ^FD STATEMENT IN THE ZPL STRING HAS AN INCORRECT CHECK DIGIT. THIS RESULTED IN THE "INVALID - E" MESSAGE BEING PRINTED IN PLACE OF THE BAR CODE.

INVALID - L

^F0220,10^BEN,100,Y,N^FD97823456789081^FS

THE ^FD STATEMENT IN THE ZPL STRING IS TOO LONG THIS RESULTED IN THE "INVALID - L" MESSAGE BEING PRINTED IN PLACE OF THE BAR CODE.

INVALID - S

^F0220,10^BEN,100,Y,N^FD97823456789^FS

THE ^FD STATEMENT IN THE ZPL STRING IS TOO SHORT THIS RESULTED IN THE "INVALID - S" MESSAGE BEING PRINTED IN PLACE OF THE BAR CODE.

Bar Codes

THIS PAGE INTENTIONALLY LEFT BLANK

Graphic Instructions

In addition to text and bar codes, three types of graphics can be printed on a Zebra printer:

- Boxes and lines.
- ZPL II label formats saved as graphic images.
- Graphic images in Hexadecimal format.

ZPL II has a format instruction that will create boxes and lines as part of any label format. These label formats can also be stored as graphic images and data can be merged with them at print time. Additionally, ZPL II will permit the printing of graphic images from other sources that have been created in (or converted to) hexadecimal (HEX) format. Such graphic images can come from a variety of sources, including CAD programs, draw and paint programs, and scanned images.

This chapter describes the ZPL II instructions necessary for working with graphics.

Boxes and Lines

^GB

The **^GB** (Graphic Box) instruction is used to draw boxes and/or lines as part of a label format. Boxes and lines can be used to highlight important information, divide labels into distinct areas, or just dress up the way the label looks.

The same format instruction is used for drawing either boxes or lines.

The format for the **^GB** instruction is:

^GBw,h,m,c

where

- ^GB** = Graphic Box
- w** = Width of box (in dots)
Default value: Value used for thickness or 1 dot
Minimum value: 1 dot
Maximum value: 9999 dots
- h** = Height of box (in dots)
Default value: Value used for thickness or 1 dot
Minimum value: 1 dot
Maximum value: 9999 dots
- m** = Thickness of line (in dots)
Default value: 1 dot
Minimum value: 1 dot
Maximum value: 9999 dots
- c** = Line Color
Default value: B = Black
Other value: W = White

For the **w** and **h** parameters, keep in mind that printers will have a default of 6, 8, or 12 dots/millimeter. This comes out to 153, 203 or 300 dots per inch. To determine the values for **w** and **h**, figure out the dimensions in millimeters and multiply by 6, 8 or 12.

Note: Examples on the next page were designed for a printer using an 8 dot/mm printhead.

GRAPHIC INSTRUCTIONS

Example for Drawing a Box

The following are the instructions to draw a box 1 inch high, 1.5 inches wide, and a line thickness of 10 dots.

```
^XA  
^FO150,100  
^GB305,203,10  
^XZ
```

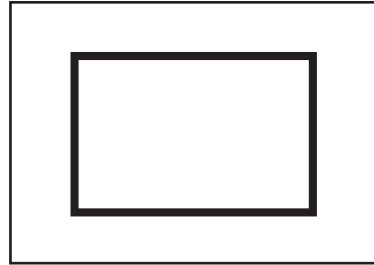

Example for Drawing a Vertical Line

The following are the instructions to draw a vertical line 1 inch high with a line thickness of 20 dots.

```
^XA  
^FO150,100  
^GB0,203,20  
^XZ
```



Example for Drawing a Horizontal Line

The following are the instructions to draw a horizontal line 1 inch long with a line thickness of 30 dots.

```
^XA  
^FO150,100  
^GB203,0,30  
^XZ
```



Working with Hex Graphic Images

ZPL II can be used to save graphic images in HEX format in DRAM. The image might be created using a CAD program, a draw or paint program, or a scanner. These images can then be printed on the label.

The images must already be coded in HEX, or converted to HEX using a graphics utility program, since ZPL II does not provide this capability. Manually preparing a string of HEX code is possible but usually impractical.

Downloading a Graphic Image

~DG

The **~DG** (Download Graphic) instruction performs the following functions:

1. Puts the printer into Graphics Mode.
2. Names the graphic. (This name is used to recall it into a label.)
3. Defines the size of the graphic.
4. Downloads the HEX string to the printer.

Note 1: As far as the printer is concerned, the name used for the graphic image will end at a space, period, or extension.

Note 2: To avoid accidental replacement of graphics due to spaces in the names, do not use spaces in graphic names. Always use different names for different graphics.

Note 3: If two graphics with the same name are sent to the printer, the first graphic will be erased and replaced by the second graphic.

GRAPHIC INSTRUCTIONS

The format for the **~DG** instruction is:

~DG<{**Dst:**}**Objectname**{**.ext**}>,t,w,<**DATA**>

where

~DG	=	Set printer to download graphic mode
{ Dst: }	=	Destination device to store image. <i>Default value: R:(DRAM)</i> <i>Other value: B:(Optional Memory)</i>
Objectname	=	Name of image, 1-8 alphanumeric characters. <i>(Default, the name "UNKNOWN" is used.)</i>
{ .ext }	=	Extension, 3 alphanumeric characters <i>{Fixed. Will always be .GRF}</i>
t	=	Total number of bytes in graphic
w	=	Number of bytes per row
< DATA >	=	ASCII Hexadecimal string that defines image

If the **Objectname** is omitted, the default name "UNKNOWN.GRF" will be used. The **DATA** string which defines the image is an ASCII Hexadecimal representation of the image. Each character represents a horizontal nibble of four dots.

The following is an example of using the **~DG** instruction to load a checkerboard pattern into DRAM. The name used to store the graphic is **SAMPLE.GRF**.

```
~DGR:SAMPLE.GRF,00080,010,  
FFFFFFFFFFFFFFFFFFFF  
8000FFFF0000FFFF0001  
8000FFFF0000FFFF0001  
8000FFFF0000FFFF0001  
FFFF0000FFFF0000FFFF  
FFFF0000FFFF0000FFFF  
FFFF0000FFFF0000FFFF  
FFFFFFFFFFFFFFFFFFFF
```

GRAPHIC INSTRUCTIONS

The “t” parameter (the total number of bytes in a graphic) can be determined by using the following formula:

$$\frac{x \times (\text{dots/mm})}{8(\text{bits/byte})} \times (y \times (\text{dots/mm})) = \text{total bytes}$$

where x is the width of the graphic in millimeters, y is the height of the graphic in millimeters and dots/mm is the print density of the printer being programmed.

For example, to determine the correct t parameter for a graphic 8mm wide, 16mm high and a print density of 8 dots/mm, the formula works this way:

$$\left(\frac{8 \times 8}{8} \right)^* \times (16 \times 8) = \text{total bytes}$$

$$8 \times 128 = 1024 \text{ bytes}$$

$$t = 1024$$

Note: * Raise any portion of a byte to the next whole byte.

The “w” parameter (the width in terms of bytes per row) can be determined by using the following formula:

$$\frac{x \times (\text{dots/mm})^*}{8} = \text{total bytes per row}$$

where x is the width of the graphic in millimeters and dots/mm is the print density of the printer being programmed.

For example, to determine the correct w parameter for a graphic 8mm wide and a print density of 8 dots/mm, the formula works this way:

$$\frac{8 \times 8}{8} = 8 \text{ bytes}$$

$$w = 8$$

Note 1: Raise any portion of a byte to the next whole byte.

Note 2: ‘w’ is the first value in the ‘t’ calculation.

GRAPHIC INSTRUCTIONS

Parameter *<DATA>* is a string of Hexadecimal numbers sent as a representation of the graphic image. Each Hexadecimal character represents a horizontal nibble of four dots. For example, if the first four dots of the graphic image to be created should be white and the next four black, the dot by dot Binary code would be 00001111. The Hexadecimal representation of this Binary value would be 0F. The entire graphic image is coded in this way. The complete graphic image is sent as one long continuous string of Hexadecimal values.

Alternative Data Compression Scheme for ~DG and ~DB Instructions

There is an alternative data compression scheme recognized by the Zebra printer. This scheme further reduces the actual number of data bytes and the amount of time required to download graphic images and bit-mapped fonts with the **~DG** and **~DB** instructions.

The following represent the repeat counts 1,2,3,4,5,.....,19 on a subsequent Hexadecimal value. (**Note:** Values start with G since 0 thru 9 and A thru F are already used for HEX values.)

G	H	I	J	K	L	M	N	O	P	Q	R	S	T	U	V	W	X	Y
1	2	3	4	5	6	7	8	9	10	11	12	13	14	15	16	17	18	19

Example: Sending a M6 to the printer is identical to sending the following Hexadecimal data:

6666666

The "M" has the value of 7. Therefore "M6" sends seven (7) hexadecimal 6's.

g	h	i	j	k	l	m	n	o	p	q
20	40	60	80	100	120	140	160	180	200	220
r	s	t	u	v	w	x	y	z		
240	260	280	300	320	340	360	380	400		

represent the repeat counts 20, 40, 60, 80,....400 on a subsequent Hexadecimal value.

GRAPHIC INSTRUCTIONS

Example: Sending a hB to the printer is identical to sending the following HEX data:

BB

The “h” has the value of 40. Therefore “hB” sends forty (40) hexadecimal B’s.

Repeat Values.....

Several repeat values can be used together to achieve any value desired. “vMB” or “MvB” will send 327 hexadecimal B’s to the printer.

a comma (,) fills the line, to the right, with zeros (0) until the specified line byte is filled.

an exclamation mark (!) fills the line, to the right, with ones (1) until the specified line byte is filled.

a colon (:) denotes repetition of the previous line.

~DN

After decoding and printing the number of bytes in parameter *t*, the printer returns to normal print mode. Graphics Mode can be aborted and normal printer operation resumed, by using the **~DN** (Abort Download Graphic) instruction.

The format for the **~DN** instruction is:

~DN

where

~DN = Abort Download Graphic

Note: Any ^ or ~ instruction will also end the download

Reducing Download Time of Graphic Images

There is a method of reducing the actual number of data bytes sent to the printer when using the ~DG instruction. This is shown in Figures 6.1 and 6.2 along with the graphic.

In figure 6.2, if the HEX string ends in an even number of 0's (zeros), a single comma (,) can be substituted for ALL of the zeros. If the HEX string ends in an odd number of zeros, one zero and a single comma is required. The exclamation mark (!) and the colon (:), described under 'Repeat Values' on page 6-8 can also be used.

CAUTION: The text rows in your editor may not be the same as the dot rows used by ZPL II. The editor may word wrap or truncate the dot rows. ZPL II ignores the end of a text line (ie. carriage returns and line feed characters).

Note: In Figures 6.1 and 6.2, carriage returns have been inserted at the end of every dot row for visual clarity.

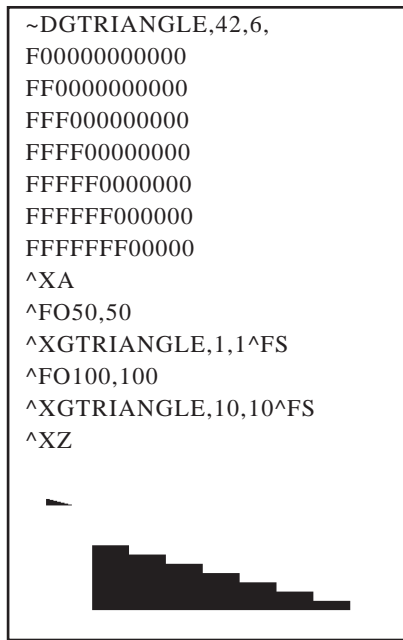

Figure 6.1 Complete Graphic Coding

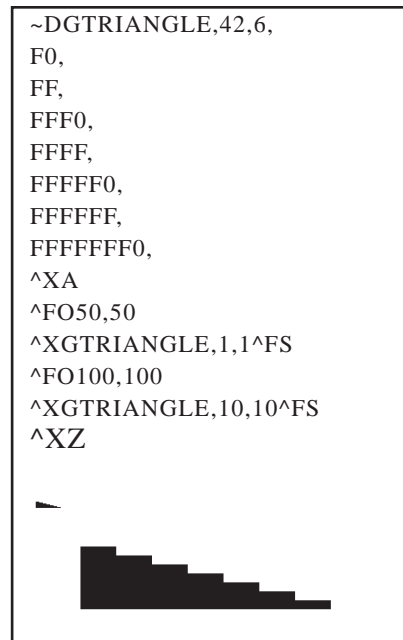

Figure 6.2 Condensed Graphic Coding

Graphic Instructions

Recalling a Hexadecimal Graphic Image

^XG

The **^XG** (Recall Graphic) instruction is used to recall one or more graphic images for printing. This instruction is used in a label format to merge pictures such as company logos and piece parts, with text data to form a complete label.

An image may be recalled and resized as many times per format as needed. Other images and data may be added to the format.

The format for the **^XG** instruction is:

^XG<{Src:}>**Objectname**<{.ext}>,x,y

where

^XG	=	Recall graphic image
{Src:}	=	Source device where image is stored. <i>{Optional. Default is Search Priority.}</i>
Objectname	=	Name of stored image, 1-8 alphanumeric characters. <i>(Default, the name "UNKNOWN" is used.)</i>
{.ext}	=	Extension, 3 alphanumeric characters <i>{Fixed. Will always be .GRF}</i>
x	=	Magnification factor along x-axis <i>Default value: 1 Minimum value: 1, Maximum value: 10</i>
y	=	Magnification factor along y-axis <i>Default value: 1 Minimum value: 1, Maximum value: 10</i>

The following is an example of using the **^XG** instruction to recall the image SAMPLE.GRF from DRAM and print it in 5 different locations and 5 different sizes on the same label:

```

^XA
^FO100,100^XGR:SAMPLE.GRF,1,1^FS
^FO100,200^XGR:SAMPLE.GRF,2,2^FS
^FO100,300^XGR:SAMPLE.GRF,3,3^FS
^FO100,400^XGR:SAMPLE.GRF,4,4^FS
^FO100,500^XGR:SAMPLE.GRF,5,5^FS
^XZ
    
```

Image Move

The **^IM** (Image Move) instruction performs a direct move of an image from storage area into the bitmap. The instruction is identical to the Recall Graphic instruction except that there are no sizing parameters.

The format for the **^IM** instruction is:

^IM

^IM<{Src:}>**Objectname**<{.ext}>

where

- ^IM** = Move image to bitmap.
- {Src:}** = Source device where image is stored.
{Optional. Default is Search Priority.}
- Objectname** = Name of stored image, 1-8 alphanumeric characters. *(Default, the name "UNKNOWN" is used.)*
- {.ext}** = Extension, 3 alphanumeric characters
{Fixed. Will always be .GRF}

Note 1: By using the **^FO** instruction, the graphic image can be positioned anywhere on the label.

Note 2: The difference between **^IM** and the **^XG** instruction is that the Image Move instruction does not have magnification, and therefore may require less formatting time. However, to take advantage of this, the image must be at a 8, 16 or 32 "bit boundary".

The following example moves the image SAMPLE.GRF from DRAM and prints it in 5 locations in its original size.

```

^XA
^FO100,100^IMR:SAMPLE.GRF^FS
^FO100,200^IMR:SAMPLE.GRF^FS
^FO100,300^IMR:SAMPLE.GRF^FS
^FO100,400^IMR:SAMPLE.GRF^FS
^FO100,500^IMR:SAMPLE.GRF^FS
^XZ
    
```

Working with Label Formats as Graphics

The **^IS** (Image Save) and **^IL** (Image Load) instructions are used to save a ZPL label format (including text and/or bar codes) in the printer's DRAM as a special graphic image. This lets you increase the throughput of a series of similar but not identical labels.

Instead of formatting each individual label completely, store the constant fields as an image (i.e create a template). Then, in subsequent label formats, instructions are issued to recall that graphic image format and merge it with variable data.

Saving Label Formats in Memory as Graphic Images

^IS

The **^IS** (Image Save) instruction is used within a ZPL II label format to save that format as a graphic image. This instruction is used within a label format, typically at the end. It instructs the printer to save that label format as a graphic image rather than a ZPL II script file. The image can later be recalled with virtually no formatting time and overlaid with variable data to form a complete label.

Using this technique to overlay the image of constant information with the variable data greatly increases the throughput of the label format. If the Objectname is omitted, the default name "UNKNOWN.GRF" will be used.

The format for the **^IS** instruction is:

^IS<{Dst.}>Objectname<{.ext}>,x

where

- ^IS** = Save format as a graphic image.
- {Dst.}** = Destination device to store image.
Default value: R:(DRAM)
Other value: B:(Optional Memory)
- Objectname** = Name of image, 1-8 alphanumeric characters.
(Default, the name "UNKNOWN" is used.)
- {.ext}** = Extension, 3 alphanumeric characters
{Fixed. Will always be .GRF}
- x** = Print image after storing
Default value: Y = Yes
Other value: N = No

GRAPHIC INSTRUCTIONS

The following is an example of using the **^IS** instruction to save a label format to DRAM. The name used to store the graphic is **SAMPLE2.GRF**.

```
^XA
^LH10,15^FWN^BY3,3,85^CFD,36
^GB430,750,4^FS
^FO10,170^GB200,144,2^FS
^FO10,318^GB410,174,2^FS
^FO212,170^GB206,144,2^FS
^FO10,498^GB200,120,2^FS
^FO212,498^GB209,120,2^FS
^FO4,150^GB422,10,10^FS
^FO135,20^A0,70,60^FDZEBRA^FS
^FO80,100^A0,40,30^FDTECHNOLOGIES CORP^FS
^CFD,18,10^FS^FO15,180^FDARTICLE #^FS
^FO218,180^FDLOCATION^FS^FO15,328^FDDDESCRIPTION^FS
^FO15,508^FDREQ. NO.^FS^FO220,508^FDWORK NUMBER^FS
^FO15,630^AD,36,20^FDCOMMENTS:^FS
^ISR:SAMPLE2.GRF,Y
^XZ
```

The following is another example of a label format that might be saved as a graphic image.

Sending the following data to the printer will create the label format shown to the right.

```
^XA
^LH100,100^FS
^FXSHIPPING LABEL^FS
^FO10,10^GB470,280,4^FS
^FO10,190^GB470,4,4^FS
^FO10,80^GB240,2,2^FS
^FO250,10^GB2,100,2^FS
^FO250,110^GB226,2,2^FS
^FO250,60^GB226,2,2^FS
^FO156,190^GB2,95,2^FS
^FO312,190^GB2,95,2^FS
^XZ
```

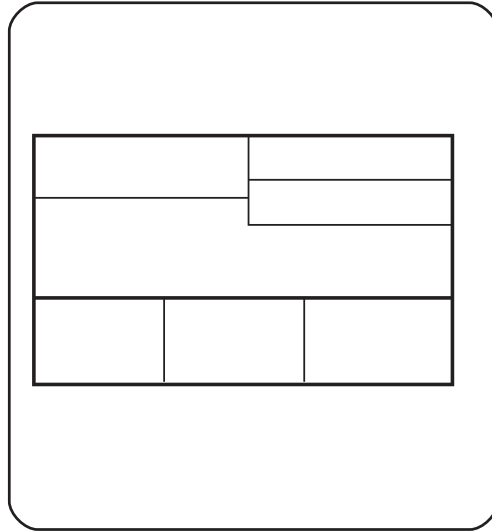

Graphic Instructions

Recalling Label Formats from Memory

^IL

The **^IL** (Image Load) instruction is used at the beginning of a label format to load a stored image of a format and merge it with additional data. The image is always positioned at **^FO0,0**.

Using this technique to overlay the image of constant information with the variable data greatly increases the throughput of the label format.

The format for the **^IL** instruction is:

^IL<{Src:}>Objectname<{.ext}>

where

^IL	=	Load graphic image to bitmap.
{Src:}	=	Source device where image is stored. <i>{Optional. Default is Search Priority.}</i>
Objectname	=	Name of stored image, 1-8 alphanumeric characters. <i>(Default, the name "UNKNOWN" is used.)</i>
{.ext}	=	Extension, 3 alphanumeric characters <i>{Fixed. Will always be .GRF}</i>

The following example would recall the stored image SAMPLE2.GRF from DRAM and overlay it with the additional data.

```

^XA
^ILR:SAMPLE2.GRF^FS
^CFD,36,20
^FO15,210^FD900123^FS
^FO218,210^FDLINE 12^FS
^FO15,360^AD^FDZEBRA THERMAL^FS
^FO15,400^AD^FDTRANSFER PRINTER^FS
^FO15,540^FD54321^FS
^FO220,530^FDZ58643^FS
^FO15,670^A0,27,18^FDTesting Stored Graphic^FS
^FO15,700^A0,27,18^FDLabel Formats!!
^XZ
    
```

Transferring Objects Between Storage Devices

Transfer Object

The **^TO** (Transfer Object) instruction is used to copy an object or group of objects from one storage device to another. It is quite similar to the copy function used in PC's.

(Not applicable to Zebra STRIPE Printers)

Source and destination devices must be supplied and must be different and valid for the action specified. Invalid parameters will cause the instruction to be ignored.

There are no defaults associated with this instruction. However, the asterisk (*) may be used as a wild card for Objectnames and extensions. For instance, ZEBRA.* or *.GRF would be acceptable forms for use with **^TO** instruction.

The format for the **^TO** instruction is:

^TO

^TO{Src:}Objectname{.ext},{Dst:}Objectname{.ext}

where:

^TO	=	Transfer Object.
{Src:}	=	Source device where object is stored. {R:, B:}
Objectname	=	Name of stored object. (Supports use of <i>wild cards</i> .)
{.ext}	=	Extension, 3 alphanumeric characters. (Supports use of <i>wild cards</i>)
{Dst:}	=	Destination device where object is to be stored. {R:, B:}
Objectname	=	Name of object stored at destination. (Supports use of <i>wild cards</i> .)
{.ext}	=	Extension, 3 alphanumeric characters. (Supports use of <i>wild cards</i>)

Note 1: If the destination device does not have enough free space to store the object being copied, the entire operation will be negated.

Note 2: Zebra Files (Z:*.*) cannot be transferred. These files are copyrighted by Zebra Technologies Corp.

The following are some examples of using the ^TO instruction.

To copy the object ZLOGO.GRF from DRAM to an optional Memory Card and rename it ZLOGO1.GRF:

^XA

^TOR:ZLOGO.GRF,B:ZLOGO1.GRF

^XZ

To copy the object SAMPLE.GRF from an optional Memory Card to DRAM and keep the same name

^XA

^TOB:SAMPLE.GRF,R:SAMPLE.GRF

^XZ

Transferring Multiple Objects

The Asterisk (*) can be used to transfer multiple object files (except *.FNT) from the DRAM to the Memory Card. For example, you have several object files that contain logos. These files are named LOGO1.GRF, LOGO2.GRF, and LOGO3.GRF.

For example...

You want to transfer all of these files to the Memory Card using the name NEW instead of LOGO. By placing an Asterisk (*) after both LOGO and NEW in the transfer instruction, you can copy all of these files with one instruction. The format for this would be as follows.

^XA

^TOR:LOGO*.GRF,B:NEW*.GRF

^XZ

Note: If, during a multiple transfer, a file is too big to be stored on the Memory Card, it will be skipped. All remaining files will be checked to see if they can be stored. Those that can be stored, will be stored.

Deleting Graphics from Memory

The **^ID** (Item Delete) instruction deletes objects, images, fonts, formats etc. from storage areas selectively or in groups. This instruction can be used within a printing format to delete objects just prior to saving new ones or can be in a stand-alone type format simply to delete objects.

The Objectname and extension support the use of the asterisk (*) as a wildcard. This allows for easy deletion of selected groups of objects.

The format for the **^ID** instruction is:

^ID

^ID<{Src.}>**Objectname**<{.ext}>

where

- ^ID** = Delete image (object).
- {Src.}** = Source device where object is stored. {R:, B:}
- Objectname** = Name of stored image, 1-8 alphanumeric characters. (Default, the name "UNKNOWN" is used.)
- {.ext}** = Extension, 3 alphanumeric characters {Default is .GRF}

The following are various examples of using the **^ID** instruction.

To delete just stored formats from DRAM:

```
^XA^IDR:*.ZPL^XZ
```

To delete formats and images named SAMPLE from DRAM regardless of the extension:

```
^XA^IDR:SAMPLE.*^XZ
```

To delete the image SAMPLE1.GRF prior to storing SAMPLE2.GRF:

```
^XA
^FO25,25^AD,18,10^FDDelete^FS
^FO25,45^AD,18,10^FDthen Save^FS
^IDR:SAMPLE1.GRF^FS
^ISR:SAMPLE2.GRF^FS
^XZ
```

To delete everything from DRAM:

```
^XA^IDR:.*^XZ
```

GRAPHIC INSTRUCTIONS

Deleting all Graphic Images from DRAM

~EG

OR

^EG

The **~EG** or **^EG** (Erase Downloaded Graphics) instruction is used to delete all graphic images (label format images and hexadecimal images) from DRAM.

The format for the **~EG** or **^EG** instruction is:

~EG or ^EG

where

~EG, ^EG = Erase Downloaded Graphics

Advanced Techniques

Previous chapters have presented the basic instructions needed to create labels with ZPL II. This chapter presents information and instructions for using more advanced techniques such as special effects, non-printing comments, serialized data fields, control instructions, and program delimiters.

Nonprinting Comments

The **^FX** (Comment) instruction is useful when you want to add a “non-printing” informational comment or statement within a label format. Any data after the **^FX** instruction up to the next caret or tilde instruction will not have any effect on the label format.

The format for the **^FX** instruction is:

^FX<data>

^FX

where

^FX = Comment

<data> = A “non-printing” instructional comment or statement.

The following is an example of how to use the **^FX** instruction.

Note: It is a good practice to always follow the data with a **^FS** instruction.

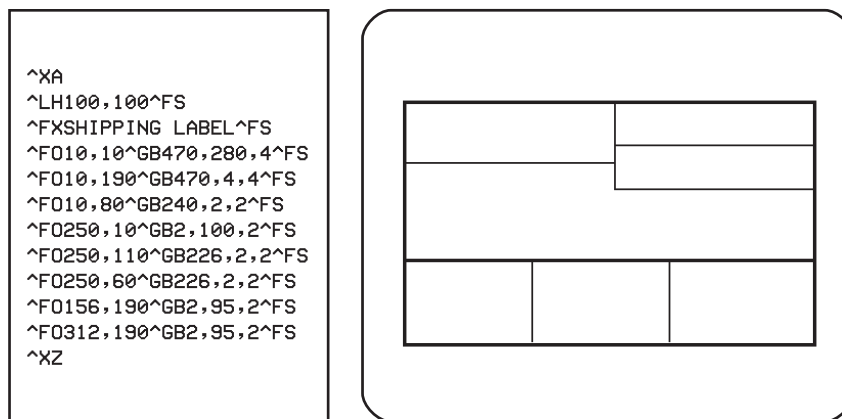

Special Effects for Print Fields

ZPL II includes a few “Special Effects” instructions.

Reverse Printing a Field

^FR

The **^FR** (Field Reverse Print) instruction allows a field to appear as white over black or black over white. When printing a field, if the dot to print is black, it is made white; if the dot is white, it is made black.

The format for the **^FR** instruction is:

^FR

where

^FR = Field Reverse Print

```

^XA
^F0100,60
^GB380,203,203^FS
^F0180,110
^CFG^FR^FDFIELD^FS
^F0130,170
^FR^FDREVERSE^FS
^XZ
    
```



The following is an example of how to use the **^FR** instruction.

Note 1: Dot patterns for a particular field are placed into the bit map in the same order the fields are specified in the format instructions. Therefore, care should be taken when using more than one **^FR** instruction in a label format.

Note 2: The effects of an **^FR** instruction *will not be seen* unless it is preceded by a another field (i.e. text followed by a **^FR^GB**) as shown in the above example.

Reverse Printing a Label

The **^LR** (Label Reverse Print) instruction reverses the printing of all fields in the label format. It allows a field to appear as white over black or black over white. When printing a field, if the dot to print is black, it is made white; if the dot is white, it is made black.

Using the **^LR** is identical to placing a **^FR** in all current and subsequent fields.

The format for the **^LR** instruction is:

^LR

^LRa

where

^LR = Label Reverse Print

a = Reverse print all fields.

Y = Yes

N = No **{I.V.P. = N}**

[Instruction is ignored if no parameter given.]

The following is an example of how to use the **^LR** instruction.

```

^XA^LRY
^F0100,60
^GB195,203,195^FS
^F0180,110
^CFG^FDLABEL^FS
^F0130,170
^FDREVERSE^FS
^XZ
    
```



Note 1: The **^LR** will remain active unless turned off by **^LRN** instruction or the printer is powered down.

Note 2: The effects of an **^LR** instruction *will not be seen* unless fields overlap as shown in the above example.

Note 3: Only fields that come after this instruction will be affected.

Printing a Mirror Image

The **^PM** (Print Mirror Image of Label) instruction prints the entire printable area of the label as a mirror image. This instruction flips the image from left to right.

^PM

The format for the **^PM** instruction is:

^PMa

where

^PM = Print Mirror Image

a = Mirror print entire label.

Y = Yes

N = No **{I.V.P. = N}**

[Instruction is ignored if no parameter given.]

The following is an example of how to use the **^PM** instruction.

```
^XA^PMY  
^F0130,110  
^CFG^FDMIRROR^FS  
^F0130,170  
^FDIMAGE^FS  
^XZ  
^XA^PMN^XZ
```



Note: The **^PM** will remain active unless turned off by **^PMN** instruction or the printer is powered down.

Serialized Data

The **^SN** (Serialization Data) instruction allows the printer to index data fields by a selected increment or decrement value (i.e., make the data fields increase or decrease by a specified value) each time a label is printed. This can be performed on up to 100 to 150 fields in a given format and can be performed on both alphanumeric and bar code fields. A maximum of 12 of the right-most integers are subject to indexing. The first integer found when scanning from right to left starts the indexing portion of the data field.

If the alphanumeric field to be indexed ends with an alpha character, the data will be scanned, character-by-character, from right to left until a numeric character is encountered. Serialization will take place using the value of the first number found.

Using Leading Zeros

In the **^SN** instruction, the “z” parameter determines if leading zeros will be printed or suppressed. The default value for this parameter is to not print the leading zeros. Depending on which value is used (Y=Yes, print leading zeros; N=No, do not print leading zeros) the printer will do the following.

Printing Leading Zeros

The starting value consists of the right most consecutive sequence of digits. The width (number of digits in the sequence) is determined by scanning from right to left until the first non-digit (space or alpha character) is encountered. To create a specific width, manually place leading zeros as necessary.

Suppressing Leading Zeros

The starting value consists of the right most consecutive sequence of digits, *including any leading spaces*. The width (number of digits in the sequence) is determined by scanning from right to left until the first alpha character (except a space) is encountered. To create a specific width, manually place leading spaces or zeros as necessary. Suppressed zeros are replaced by spaces. During the serialization process, when the entire number contains all zeros, the last zero is not suppressed. In this case a single zero is printed.

Note: If, during the course of printing serialized labels the printer runs out of either paper or ribbon, the first label printed (after the media or ribbon has been replaced and calibration completed) will have the same serial number as the “partial” label printed before the “out” condition occurred. This is done in case the last label before the “out” condition did not fully print. This is controlled by the **^JZ** instruction (see Page 3-11).

^SN

The Serialize Data Instruction replaces the Field Data (**^FD**) instruction within a label formatting program.

The format for the **^SN** instruction is:

^SN_{v,n,z}

where

^SN = Serialized Data

v = Starting Value
Default value: 1
Other values: 12-digit maximum for portion to be indexed.

n = Increment/Decrement Value
Default value: 1
Other values: 12-digit maximum

Note: To indicate a decrement value, precede the value with a minus sign (-).

z = Add Leading Zeros if Needed
Default value: N = No
Other value: Y = Yes

ADVANCED TECHNIQUES

The following is an example of how to use the ^SN instruction.

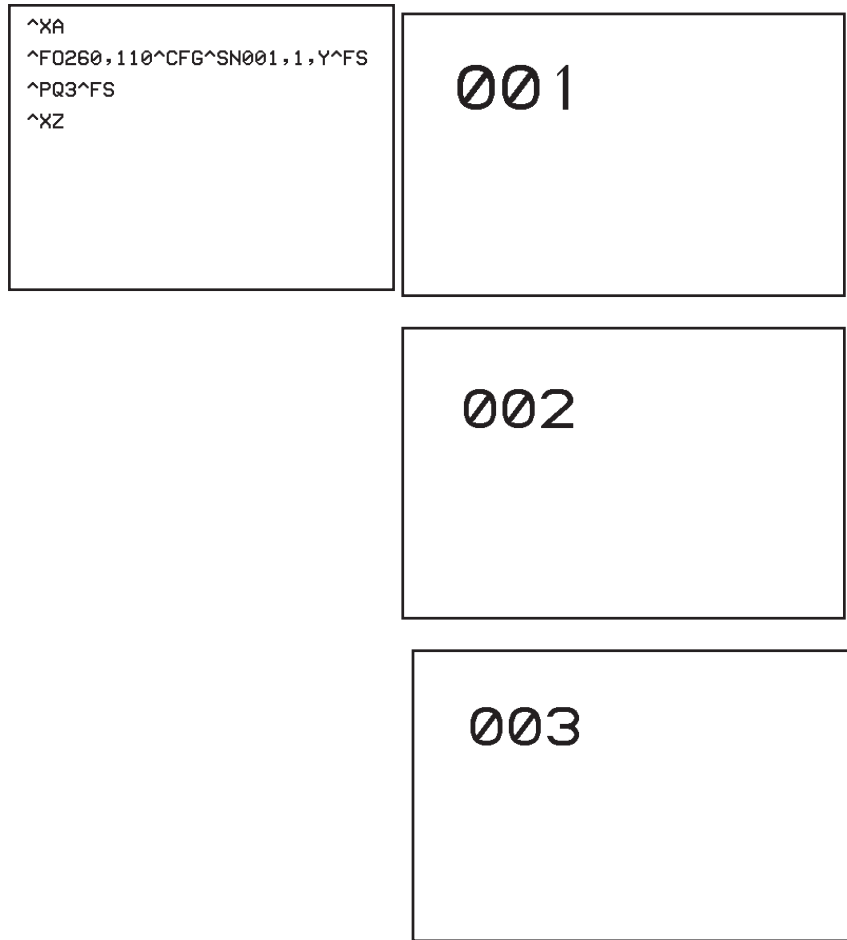

Note: Incrementing/Decrementing takes place for each serial numbered field when all replicates for each serial number have been printed, as specified in parameter “r” of the Print Quantity ^PQ instruction.

Variable Data

To increase throughput, you can set up a program that uses variable data fields. Then, instead of formatting the whole label each time a label is printed, the printer will have to format only the changed data field. To use this capability, you must use the **^MC** and **^FV** instructions.

Map Clear

In normal operation, the bit map is cleared after the format has been printed. The **^MC** (Map Clear) instruction is used to retain the current bit map. This applies to current and subsequent labels until cleared with a second **^MCY** instruction.

^MC

The format for the **^MC** instruction is:

^MCx

where

^MC = Map Clear

x = Y = Yes (Clear bit map.) **{I.V.P. = N}**
 N = No (Do not clear the bit map.)

Note: The **^MCN** instruction retains the image of the current label after formatting. It will appear in the background of the next label printed.

Variable Field Data

The **^FV** (Variable Field Data) instruction replaces the **^FD** (Field Data) instruction in a label format when the field is variable:

The format for the **^FV** instruction is:

^FV<data>

^FV

where

^FV = Field Variable Data

<data> = Variable field data to be printed. 0 to 255 character string.

[Instruction ignored if no data entered.]

The following is an example of how to use the **^MC** and **^FV** instruction.

Note: **^FV** fields are *always* cleared after the label is printed. **^FD** fields are not cleared.

<pre> ^XA ^F040,40^GB300,203,8^FS ^F055,60^FVVARIABLE DATA #1^FS ^F080,150^FDFIXED DATA ^FS ^MCN^XZ ^XA ^F055,60^FVVARIABLE DATA #2^FS ^MCY^XZ </pre>	<div style="border: 2px solid black; padding: 10px; width: 80%; margin: 0 auto;"> <p>VARIABLE DATA #1</p> <p>FIXED DATA</p> </div>
	<div style="border: 2px solid black; padding: 10px; width: 80%; margin: 0 auto;"> <p>VARIABLE DATA #2</p> <p>FIXED DATA</p> </div>

Stored Formats

You can create formats and save them in volatile memory. A stored format can then be recalled and merged with downloaded data to form a complete label. This process saves transmission time but not formatting time. It is particularly useful if you are not working with an intelligent input device.

To create a format do the following:

- Design the label.
- Replace variable data fields with field numbers.
- Allocate space for the size of the field.
- Give the format a name.
- Save the format to the printer.

You can store multiple formats, limited by available DRAM. If you try to save a format that would overload memory, that format is not stored. You *DO NOT* receive an error message that the format is not stored. You will learn that the format was not stored only when you try to recall it (and are unable to do so) or if you print the List of Formats.

If the power is turned OFF, ALL stored formats in DRAM will be lost.

Initialize/Erase Stored Formats

^EF

OR

~EF

The **^EF** or **~EF** (Erase Format) instruction erases all stored formats. If you use the erase format instruction, you erase all stored formats. (Stored formats can be selectively erased using the **^ID** instruction.)

The format of the **^EF** or **~EF** instruction is:

^EF or ~EF

where

^EF, = Erase Format
~EF

Download Format Instruction

The **^DF** (Download Format) instruction saves the ZPL II format instructions as text strings to be later merged using **^XF** with variable data. The format to be stored may contain Field Number (**^FN**) instructions to be referenced when recalled.

While use of stored formats will reduce transmission time, no formatting time is saved since this instruction saves the ZPL II as text strings which need to be formatted at print time.

If the Objectname is omitted, the default name and extension "UNKNOWN.ZPL" will be used. Enter the **^DF** (Download Format) instruction immediately after the **^XA** instruction, then enter the format instructions to be saved.

Note: A format containing a **^DF** will not print. Results are undefined for any instructions that appear prior to the **^DF** in a format.

The format for the **^DF** instruction is:

^DF

^DF<{Dst:}Objectname{.ext}>

where

- ^DF** = Download and store format
- {Dst:}** = Destination device to store image.
{Fixed. Will always be DRAM(R:)}
- Objectname** = Name of image, 1-8 alphanumeric characters.
(Default, the name "UNKNOWN" is used.)
- {.ext}** = Extension, 3 alphanumeric characters
{Fixed. Will always be .ZPL}

Example for ^DF is on the following page.

ADVANCED TECHNIQUES

The following is an example of using the **^DF** instruction to download and store ZPL II text strings to DRAM. The name used to store the text strings is STOREFMT.ZPL.

```
^XA
^DFR:STOREFMT.ZPL^FS
^FO25,25^AD,36,20^FN1^FS
^FO135,25^AD,36,20^FN2^FS
^FO25,75^AB,11,7^FDBUILT BY^FS
^FO25,100^AD,18,10^FN1^FS
^XZ
```

Field Number Instruction

The **^FN** (Field Number) instruction is used to number the data fields. This instruction is used in both Store Format and Recall Format operations.

In a stored format, the **^FN** instruction is used where you would normally use the **^FD** (Field Data) instruction. In recalling the stored format, use **^FN** in conjunction with the **^FD** (Field Data) instruction.

The format for the **^FN** instruction is:

^FNx

^FN

where

^FN = Field Number

x = Number to be assigned to the field.

Default value: 0

Other Values: Minimum=1, Maximum=9999

Note 1: The same **^FNx** value can be stored with several different fields.

Note 2: If a label format contains a field with an **^FNx** and an **^FD**, the data in that field will be printed for any other field containing the same **^FNx** value.

Field Allocate

Use the **^FA** (Field Allocate) instruction to allocate space for the field to be saved.

The format for the **^FA** instruction is:

^FAx

^FA

where

^FA = Field Allocate

x = Number of character spaces to be saved

Default value: None. Instruction is ignored if no value is specified.

Minimum=1, Maximum=256

Recall Stored Format Instruction

The **^XF** (Recall Format) recalls a stored format to be merged with variable data. There can be multiple **^XF** instructions and they can be located anywhere in the label format.

When recalling a stored format and merging data utilizing the **^FN** (Field Number) function, the calling format must contain the (**^FN**) instruction to properly merge the data.

While use of stored formats will reduce transmission time, no formatting time is saved since the ZPL II format being recalled was saved as text strings which need to be formatted at print time.

The format for the **^XF** instruction is:

^XF

^XF<{Src:}Objectname{.ext}>

where

- ^XF** = Recall Stored Format
- {Src:}** = Source device of stored image.
{Optional. Default is Search Priority}
- Objectname** = Name of stored image, 1-8 alphanumeric characters. *(Default, the name "UNKNOWN" is used.)*
- {.ext}** = Extension, 3 alphanumeric characters
{Fixed. Will always be .ZPL}

The following is an example of using the **^XF** instruction to recall the format STOREFMT.ZPL from DRAM and also send new reference data:

```

^XA
^XFR:STOREFMT.ZPL^FS
^FN1^FDZEBRA^FS
^FN2^FDPRINTER^FS
^XZ
    
```

Local Directory List

The **^WD** (Print Directory on Label) instruction is used to print a label listing bar codes, objects stored in DRAM, or fonts (if an optional font ROM is installed in the printer).

For bar codes the list will show the name of the bar code. For fonts the list shows the name of the font, number to use with **^Ax** instruction and size. For objects stored in DRAM the list shows the name of the object, extension, size and option flags. All lists are enclosed in a double line box.

The format for the **^WD** instruction is:

^WD<{Src:ObjectName.ext}>

^WD

where

- ^WD** = Print Directory on Label
- {Src:}** = Source device to store image.
{Optional. Default is Search Priority}
- ObjectName** = Name of object.
{Optional. Default is ""}. A "?" can also be used}*
- {.ext}** = Extension.

The following are examples of using the **^WD** instruction.

To print a label listing all objects in DRAM.

```
^XA^WDR:*. *
^XZ
```

To print a label listing all the bar codes.

```
^XA^WDZ:*.BAR
^XZ
```

To print a label listing all fonts.

```
^XA^WDE:
^XZ
```

ADVANCED TECHNIQUES

More Examples of Using Stored Format

Working with Stored Format instructions involves designing and saving a stored format, then recalling and merging the format with some variable data.

The following is an example of how to use the various Stored Format instructions. First, enter the following format and send it to the printer. Notice that no label is printed. (DATA Indicator went On and Off.)

```
^XA^DFFORMAT^FS  
^LH30,30  
^BY2,3,100  
^F0120,100^CFD^FN1^FA9^FS  
^F0120,160^B3^FN2^FA6^FS  
^XZ
```

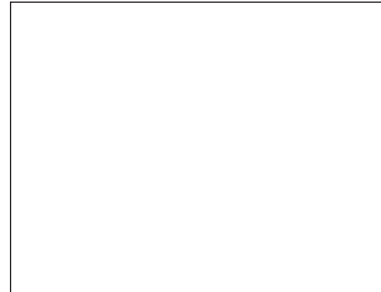

Second, enter the following format and send it to the printer. The label shown will be printed.

```
^XA^XFFORMAT^FS  
^FN1^FDLABEL ONE^FS  
^FN2^FDAAA001^FS  
^XZ
```

LABEL ONE



AAA001

Control Instructions

Control instructions may be sent from the host at any time and elicit an immediate response from the printer. Control instructions may be sent in a group or singly.

A control instruction causes the printer to take direct software action (such as clearing the memory), physical action (such as moving to next home position), or a combination (such as feeding a label and calculating and storing its length).

The basic format for using all of the control instructions is

~(instruction)

Test and Setup Instructions

~HM, ~HS, ~JR

The following instructions, presented in alphabetical order, are used to test various elements of the printer and its status.

Sending the **~HM** (Memory Status) instruction to the printer, immediately returns a memory status message to host. Use this instruction whenever you need to know the status of the memory.

See Appendix E for information on how to interpret this message.

Sending the **~HS** (Host Status) instruction to the printer, immediately returns a three-line printer status message to the host. Use this instruction whenever you need to know the status of the printer.

See Appendix D for information on how to interpret this message.

The **~JR** (Power On Reset) instruction resets all of the printer's internal software, performs a power-on self-test, clears the buffer and DRAM, and resets communication parameters and default values. **~JR** performs the same function as a manual power-on reset.

~JN, ~JO, ~JT

(Information on this page not applicable to Zebra STRIPE Printers.)

The **~JN** (Head Test Fatal) instruction resets the printhead element error override, acting as a toggle for **~JO**. Printer then goes into fault status (i.e., turns head indicator on steadily) if any subsequent execution of the printing element test detects bad printing elements.

The **~JO** (Head Test Non-Fatal) instruction overrides a failure of head element status check and allows printing to continue. The override is canceled when the printer is turned off or receives a **~JR** or **~JN** instruction. The printhead test will not produce an error if the **~JO** override is active.

The **^JT** (Head Test Interval) instruction lets you change the printhead test interval from 100 to any desired interval. The printer automatically performs an internal printhead element test which occurs every 100 labels. This takes place during formatting which minimizes a delay in printing. Therefore, the test may be performed while the printer is in PAUSE.

The format for the **^JT** instruction is:

^JTxxxx

where

^JT = Head Test Interval

xxxx = The four-digit number representing the amount of labels to be printed between tests.

Default value: 0100

Acceptable values: 0000-9999

The following instructions, presented in alphabetical order, are used to perform various media and ribbon calibrations and also set the media feed mode for the printer.

The **~JC** (Set Media Sensor Calibration) is used to force a label length measurement and recalibrate the media and ribbon sensors.

Note: In continuous mode, *only* the media and ribbon sensors will be recalibrated.

The **~JG** (Graphing Sensor Calibration) is used to force a label length measurement, recalibrate the media and ribbon sensors and print a graph (media sensor profile) of the sensor values.

The **~JL** (Set Label Length) is used to set the label length. Depending on size of label, printer will feed one or more blank labels.

The **^MF** (Media Feed) instruction dictates what happens to the media at “power up.”

The format for the **^MF** instruction is:

^MFp,h

^MF

where

- ^MF** = Media Feed
- p** = Feed action at Power Up.
Default value: F = Feed to first web after sensor.
Other values:
 C = (See **~JC** definition)
 L = (See **~JL** definition)
 N = No Media Feed
- h** = Feed action after closing print head.
Default value: F = Feed to first web after sensor.
Other values:
 C = (See **~JC** definition)
 L = (See **~JL** definition)
 N = No Media Feed

Cancel/Clear Instructions

~JA, ~JP, ~JX

The following instructions control the contents of the Zebra input buffer:

The **~JA** (Cancel All) instruction cancels all format instructions in the buffer. It also cancels any batches that may be printing.

The printer will stop printing after the current label (if one is printing) is finished printing. All internal buffers will be cleared of data. The “DATA” LED will turn off.

The **~JP**(Pause and Cancel Format) instruction, clears the format currently being processed and places the printer in the Pause mode.

The instruction clears the next format that would print, or the oldest format from the buffer. Each subsequent issuance of **~JP** clears the next buffered format until the buffer is empty. The “DATA” indicator turns off when the buffer is empty and nothing is being transmitted.

Issuing the **~JP** instruction is identical to using the Cancel switch on the printer except that the printer *does not* have to be in the Pause mode first.

The **~JX** (Cancel Current Partially Input Format) instruction cancels a format that is currently being sent to the printer.

It does not affect any formats currently being printed, or any subsequent formats that may be sent.

Printer Control Instructions

~PH, ^PH, ~PP, ^PP, ~PS

The following instructions control various printer operations.

The **~PH** or **^PH** (Slew to Home Position) instruction causes the printer to feed one blank label.

The **~PH** instruction feeds one label after the format currently being printing is done or when the printer is placed in pause.

The **^PH** instruction feeds one blank label after the format it is in prints.

The **~PP** (Programmable Pause) instruction stops printing after the current label is printed (if one is printing) and places the printer in the Pause mode.

The **^PP** (Programmable Pause) is not immediate. Therefore, several labels may be printed before a pause is performed. This instruction will pause the printer after the format it is in prints.

The operation is identical to pressing the PAUSE button on the front panel of the printer. The printer will remain paused until the PAUSE button is pressed or a **~PS** instruction is sent to the printer.

The **~PS** (Print Start) instruction causes a printer in the Pause mode to resume printing. The operation is identical to pressing the PAUSE button on the front panel of the printer when the printer is already in the Pause mode.

The **^PF** (Slew Given Number of Dot Rows) instruction causes the printer to slew labels (move labels at a high speed without printing) a specified number of dot rows, at the bottom of the label. This allows faster printing when the bottom portion of a label is blank.

The format for the **^PF** instruction is:

^PF

^PFx

where

^PF = Slew a Number of Dot Rows

x = Number of dot rows to slew.

Default value: None. Instruction is ignored if no value, or incorrect value is specified.

Acceptable values: Minimum=0,
Maximum=9999

The **^PQ** (Print Quantity) instruction gives control over several printing operations. It controls the number of labels to print, the number of labels printed before printer pauses, and the number of replications of each serial number.

This format of the **^PQ** instruction is:

^PQq,p,r,o

^PQ

where

- ^PQ** = Print Quantity
- q** = Total quantity of labels to print.
Default value: 1;
Acceptable values: 1 - 99,999,999
- p** = Pause ('group') count.
Default value: 0 = no pause;
Acceptable values: 0 - 99,999,999 labels between pauses
- r** = Replicates of each serial number
Default value: 1 = no replicates;
Acceptable values: 1 - 99,999,999 replicates
- o** = Override pause count
Default value: N = No;
Other value: Y=Yes

Explanations of Values for the ^PQ 'o' Parameter

With the 'o' parameter set to Y, the printer will NOT pause after every group count ('p' parameter) of labels has been printed. With the 'o' parameter set to N (the default), the printer will pause after every group count of labels has been printed.

Examples of the ^PQ Instruction

^PQ50,10,1,Y: Print a total quantity of 50 labels with one replicate of each serial number. Print the total quantity in groups of 10, but do not pause after every group.

^PQ50,10,1,N: Print a total quantity of 50 labels with one replicate of each serial number. Print the total quantity in groups of 10, pausing after every group.

ADVANCED TECHNIQUES

The **^PR** (Print Rate) instruction determines the media speed during printing and the slew speed (feeding a blank label).

^PR

The format for the **^PR** instruction is:

^PR*p,s*

where

^PR = Print Rate

p = Print Speed

Default value: Speed A

Acceptable values :

A or 2 50.8 mm/sec. (2 inches/sec.)

B or 3 76.2 mm/sec. (3 inches/sec.)

C or 4 101.6 mm/sec. (4 inches/sec.)

5 127 mm/sec. (5 inches/sec.)

D or 6 152.4 mm/sec. (6 inches/sec.)

E or 8 203.2 mm/sec. (8 inches/sec.)

s = Slew Speed

Default value: Speed D

Acceptable values :

A or 2 50.8 mm/sec. (2 inches/sec.)

B or 3 76.2 mm/sec. (3 inches/sec.)

C or 4 101.6 mm/sec. (4 inches/sec.)

5 127 mm/sec. (5 inches/sec.)

D or 6 152.4 mm/sec. (6 inches/sec.)

E or 8 203.2 mm/sec. (8 inches/sec.)

The printer will operate with the selected speeds until the setting is reissued in a subsequent format or the printer is turned off.

The print speed is application specific. Since print quality is affected by media and ribbon, printing speeds and printer operating modes, it is very important to run tests for your applications.

Limitations of Higher Print Speeds

Use thermal transfer mode **only**.

Horizontal bar codes with a minimum X dimension of 5 mil may be printed at print speeds of 2" (51mm) per second.

Rotated bar codes are limited to a minimum x dimension of 10mil (modulus 2) at higher print speeds. At x dimension of 5 mil (modulus 1), they may be printed at 2" per second.

Font A at a magnification of 1 is not recommended; all other fonts are acceptable.

Change Backfeed Sequence

The **~JS** (Change Backfeed Sequence) instruction is used to control the backfeed sequence. This instruction can be used on printers both with and without built-in cutters.

(Not applicable to Zebra STRIPE Printers)

The primary applications are: **1)** to allow programming of the “rest point” of the cut edge of continuous media, and **2)** provide immediate backfeed after peel-off when the printer is used in a print/apply application configuration.

This instruction only stays in effect until the printer is powered OFF, a new **~JS** instruction is sent or it is changed on the front panel. When a **~JS** instruction is encountered, it will supersede the current ‘front panel’ setting for the Backfeed Sequence.

The format for the **~JS** instruction is

~JS

~JSx

where

~JS = Change Backfeed Sequence

x = *Default value:* N=Normal operation for current printer mode

Other values:

A = Backfeed After Printing (and cutting)

B = Backfeed Before Printing (and cutting)

The front panel setting that controls the Backfeed Sequence appears on the unprotected side of the password, right after the Print Mode setting. It is displayed as

BACKFEED SEQ

The three choices are AFTER PRINT, BEFORE PRINT and DEFAULT. These front panel settings can be permanently saved.

Note: The **~JSx** instruction has replaced the **^XBA** and **^XBB** instructions (found only in ZPL Version 8.1.0). **^XB** operates normally.

The **^XB** (Suppress Backfeed) instruction suppresses forward feed of media to tear-off position depending on the current printer mode. Since no forward feed is done, a backfeed before printing of the next label is not necessary, therefore, throughput will be improved. When printing a batch of labels, the last label should not contain this instruction.

The format for the **^XB** instruction is:

^XB

where

^XB

^XB = Suppress Backfeed

In the tear-off mode:

Normal Operation - Backfeed, Print, Feed to rest
^XB Operation - Print (i.e Rewind Mode)

In the peel-off mode:

Normal Operation - Backfeed, Print, Feed to rest
^XB Operation - Print (i.e Rewind Mode)

Set Dots/Millimeter

Use the **^JM** (Set Dots/Millimeter) instruction to change the number of dots per millimeter. Depending on the print head, normal dots per millimeter on a Zebra Printer is 12-dots/mm (304-dots/inch), 8-dots/mm (203-dots/inch) or 6-dots/mm (153-dots/inch). In some applications, this high density is not required. For these applications, a lower density of 4-dots/mm (102-dots/inch) or 3-dots/mm (77-dots/inch) can be selected.

If used, this instruction must be entered before the first **^FS** instruction.

The format for the **^JM** instruction is:

^JM

^JMx

where

^JM = Set dots per millimeter

x = *Default value:* A = 12 dotd/mm, 8 dots/mm or 6 dots/mm

Other value: B = 6 dots/mm, 4 dots/mm or 3 dots/mm



Display Control Instructions

(Information on this page not applicable to Zebra STRIPE Printers.)

The **^KP** (Define Password) instruction is used to define the password that must be entered to access the front panel switches and LCD set up mode.

The format for the **^KP** instruction is:

^KP<nnnn>

^KP

where

- ^KP** = Define Password
- <nnnn>** = Mandatory four digit password.

The **^KL** (Define Language) instruction is used to select the language used for the front panel display.

The format for the **^KL** instruction is:

^KLx

^KL

where

- ^KL** = Define Language
- x** = Default value: 1 = English
Other Value: 10 = Spanish

Changing Delimiters and Instruction Prefixes

For some applications, you may need to change the ZPL II delimiter (default “,”) the format instruction prefix (default: “^”), and/or the control instruction prefix (default: “~”). You can change these characters to any ASCII characters you choose, using the appropriate instructions.

You might do this if you are using a hand-held terminal that does not have a comma to enter the ZPL II instructions, if you are working with a mainframe that has trouble processing the caret, or if you find some other character(s) easier to use.

Changing the Format Instruction Prefix

The **^CC**, **~CC** (Change Caret) instruction is used to change the format instruction prefix. The default prefix is the caret (^).

^CC

OR

~CC

The format for the **^CC**, **~CC** instruction is:

^CCx, **~CCx**

where

^CC, **~CC** = Change Caret

x = Any ASCII character.

Default value: Parameter is required. If none is used, the next character received is the new prefix character.

Note 1: ^ and ~ are interchangeable only on the **CC** command.

Note 2: Do not set any of the values to the same value as another prefix.

Changing the ZPL Delimiter Character

The **^CD, ~CD** (Change Delimiter) instruction is used to change the ZPL II delimiter character. This character is used to separate parameter values associated with several ZPL instructions. The default delimiter character is a comma (,).

The format for the **^CD, ~CD** instruction is:

^CDx, ~CDx

^CD or ~CD

where

- ^CD, ~CD** = Change Delimiter
- x** = Any ASCII character.
Default value: Parameter is required. If none is used, the next character received is the new delimiter character.

Changing the Command Instruction Prefix

The **^CT, ~CT** (Change Tilde) instruction is used to change the control instruction prefix. The default prefix is the tilde (~).

The format for the **^CT, ~CT** instruction is:

^CTx, ~CTx

^CT or ~CT

where

- ^CT, ~CT** = Change Tilde
- x** = Any ASCII character.
Default value: Parameter is required. If none is used, the next character received is the new prefix character.

To use the caret instructions, you must enclose them within format bracket instructions (**^XA** and **^XZ**; see page 2-5). For example, to change the format instruction prefix to a slash (/) and the delimiter character to (+), you would include in a program a line like this:

^CD+^CC/

You would then use **/XA** and **/XZ** to bracket the rest of the program, since you had changed the format instruction prefix.

Communication Diagnostics Instructions

Zebra printers support communication diagnostics through both hardware and software control. You can use these diagnostics to troubleshoot programs.

~JD

The **~JD** (Enable Communications Diagnostics) instruction initiates a diagnostic mode that produces an ASCII printout (using current label length and full width of printer) of all characters received by the printer. This printout includes the ASCII Characters, the HEX value and any communication errors.

~JE

The **~JE** (Disable Diagnostics) instruction cancels the diagnostic mode and returns the printer to normal label printing.

Host Status Instructions

Host Directory List

The **^HW** (Host Directory List) is used to transmit a Directory Listing of objects in a specific memory area (storage device) back to the Host computer (the device providing input to the printer). This instruction will return a formatted ASCII string of object names to the HOST via the primary serial port.

Each parameter on a line is of fixed length, and the total length of a line is also fixed. Each line listing an object begins with the asterisk (*) followed by a blank space. There are then 8 spaces for the Objectname, a period and three spaces for the extension. The extension is followed by 2 blank spaces, then 6 spaces for the object size, 2 blank spaces and 3 spaces for option flags (reserved for future use). The format looks like this.

```
<STX><CR><LF>
- DIR R:          xx<CR><LF>
* Objectname.ext(2sp.)(6 obj. sz. )(2sp.)(3 option flags)<CR><LF>
* Objectname.ext(2sp.)(6 obj. sz. )(2sp.)(3 option flags)<CR><LF>
<CR><LF>
- xxxxxx bytes free <CR><LF>
<ETX>
```

Note: <STX> = Start of Text, <CR><LF> = Carriage Return/Line Feed, <ETX> = End of Text

The instruction may be used in a stand-alone type file to be issued to the printer at any time. The printer will return the directory listing as soon as possible based on other tasks it may be performing when the instruction is received.

Note: Remember, this instruction is processed in the order it is received by the printer, unlike the **~HS** which is processed immediately.

The format for the **^HW** instruction is:

^HW<{Src:ObjectName.ext}>

^HW

where

- ^HW** = Return Directory Listing to Host
- {Src:}** = Source device of object listings.
{Optional. Default is DRAM}
- ObjectName** = Name of object.
{Optional. Default is “*”. A “?” can also be used.}
- {.ext}** = Extension.
{Optional. Default is “*”. A “?” can also be used.}

The following is an example of using the **^HW** instruction.

To send a listing of all objects in DRAM to the Host:

```
^XA^HWR:.*^XZ
```

Host Identification

~HI

The ~**HI** (Host Identification) instruction is designed to be sent from the Host to the Zebra printer to find out the type of Zebra printer. Upon receipt, the Zebra printer will respond to the Host with the following information.

XXXXXX,V1.0.0,12,512KB,x

XXXXXX = Model of Zebra printer

V1.0.0 = Version of software

12 = Dots/mm

512 or 1024KB = Memory

x = recognizable options

Host Verification

The ^**HV** (Host Verification) instruction is used to return data from specified fields, along with an optional ASCII header, to the host. It can be used with any field that has been assigned a number with the ^**FN** instruction (See Page 7-12)

The format for the ^**HV** instruction is:

^**HV***x,y,<ASCII>*

^HV

where

- ^HV** = Host Verification
- x** = Specified field number.
Default value: 0;
Acceptable values: 0-9999.
- y** = Number of characters to be returned.
Default value: 8 characters;
Acceptable values: 0 - 256.
- <ASCII>** = Header (in uppercase ASCII characters)
Default Value: None;
*Acceptable values: 0-256 characteb*s

Print Configuration Label

~WC

The **~WC** (Print Configuration Label) instruction is used to generate a Printer Configuration Label.

NOTE: This instruction only works when the printer is idle.

Start Print

The **^SP** (Start Print) instruction allows a label to start printing at a specified point before the entire label has been completely formatted. On extremely complex labels, this instruction can increase the overall throughput of the print.

The instruction works as follows. You specify the dot row at which the **^SP** instruction is to take affect. This then creates a label 'segment.' Once the **^SP** instruction is processed, all information in that segment will be printed. During the printing process, all of the instructions after the **^SP** will continue to be received and processed by the printer.

If the segment after the **^SP** instruction (or the remainder of the label) is ready for printing, media motion does not stop. If the next segment is not ready, the printer will stop "mid-label" and wait for the next segment to be completed. Precise positioning of the **^SP** instruction is somewhat of a trial-and-error process as it depends primarily on print speed and label complexity.

The **^SP** instruction can be effectively used to determine the worst case print quality. You can determine if using the **^SP** instruction is appropriate for the particular application by using the following procedure. If you send the label format up to the first **^SP** instruction and then wait for printing to stop before sending the next segment, the printed label will be a sample of the worst case print quality. It will also drop any field that is out of order.

Note: If you use the procedure in the above paragraph, the end of the label format must be as follows:

^SP#^FS

ADVANCED TECHNIQUES

In the following illustration, a label 800 dot rows in length has an **^SP500** instruction. Segment 1 will print while instructions in Segment 2 are being received and formatted.

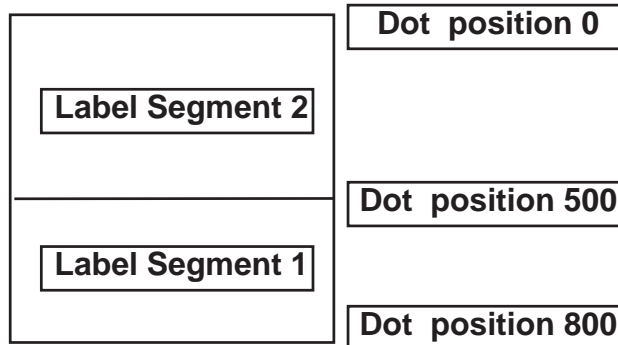

The format for the **^SP** instruction is:

^SPx

where

^SP

^SP = Start Print

x = The dot row at which printing is to start.

Default value: 0

*Other values: Any number up to that used in the
^LL (Label Length) instruction.*

Networking

~NC, ^NI, ~NT, ~NR

NOTE: NETWORKING INSTRUCTIONS ARE FUNCTIONAL ONLY ZPL II VERSIONS HIGHER THAN 14.0.1.

If your printer is equipped with an RS-232C interface port, it can be used as the *last printer* in a daisy-chained Selective Calling Network of other Zebra printers. All other printers in the network must have two RS-232C interface ports.

Special considerations for using a Zebra STRIPE printer on a network:

- The printer *must be the last* printer in the chain.
- The printer must be programmed with a unique I.D. number. This number is assigned by using the ^NI instruction.
- Only one printer can communicate with the host at any given time.

Assigning a Printer ID

The ^NI (Network ID Number) instruction is used to assign a Network ID number to the printer. This must be done before the printer can be used in a network.

^NI

The format for the ^NI instruction is:

^NIxxx

where

^NI = Network ID Number

xxx = The I.D. number to be assigned to the printer.
Factory Default value: 000 (same as None)
Acceptable values: 001–250

Note: Values must be three digit numbers or they will be ignored. If this happens, last ^NI value is used.

Note: The last Network ID Number set will be the one recognized by the system.

Connecting Printers into the Network

The **~NC** (Network Connect) instruction is used to connect a particular printer into the network by calling up the printer's Network ID Number.

The format for the **~NC** instruction is:

~NCxxx

~NC

where

- ~NC** = Network Connect
- xxx** = The Network I.D. number assigned to the printer.

Default value: 000 (same as None)
Acceptable values: 001–250

Use this instruction at the beginning of any label format to specify which printer on the network is to be used. This instruction **MUST** be included in all label formats to “wake up the printer.” This number must be three digits in length.

Set All Printers Transparent

The **~NR** (Set all Network Printers Transparent) instruction sets all printers in the network, regardless of ID or current mode, transparent.

The format for the **~NR** instruction is:

~NR

~NR

Set Currently Connected Printer Transparent

The **~NT** (Set Network Printer Transparent) instruction sets the currently connected network printer transparent.

The format for the **~NT** instruction is:

where

- ~NT** = Set Network Printer Transparent

~NT

How to Set Up a Network

To set up a network, the following steps are necessary:

- 1) Power all printers OFF and back ON.
- 2) Give the first printer a unique 3-digit number. All Zebra printers shipped from the factory are assigned unit I.D. number 000. You can assign an I.D. number (001–250) to each Zebra printer. This is particularly important if you are using a computer network.
- 3) Use **~NT** to place the printer in Step 2 into the transparent mode.
- 4) Repeat steps 2 and 3 as necessary until each printer on the network has a unique, assigned number.

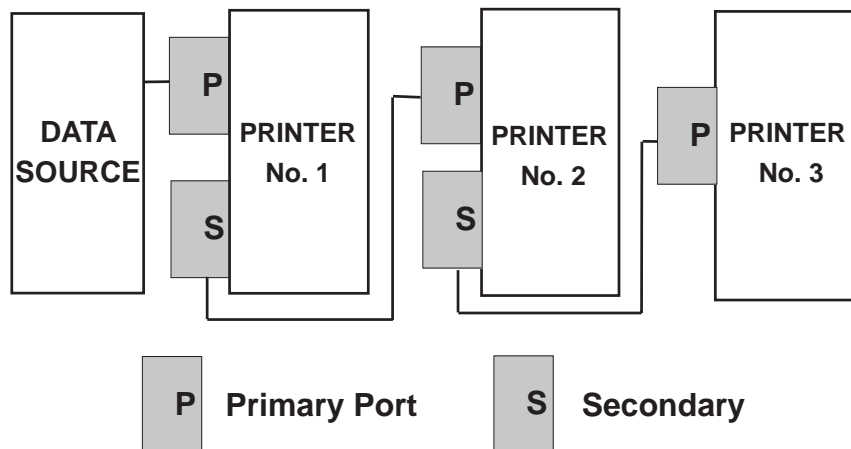

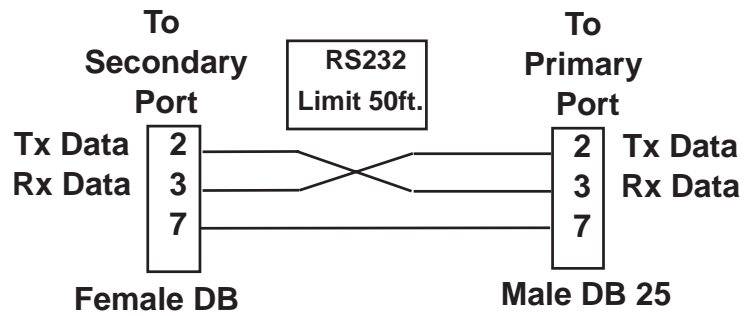

Network Cable Requirements

Network Use

To use printers in a network, do the following:

- 1) Use `~NC` with a three-digit printer number to specify the printer to be used.
- 2) Set the first printer used to transparent mode, with `~NT`, so that you can go on to another printer.

Repeat steps 1 and 2 as you move down your network.

Note: If you turn off a printer in a network, all printers beyond the one turned off will no longer be accessible.

THIS PAGE INTENTIONALLY LEFT BLANK

Programming Exercises

Introduction

These programming exercises have been included to assist and instruct both the new and more experienced user in the use of various ZPL II instructions. If you're a new user, you may find it helpful to complete all of the exercises. The exercises have been designed for simplicity so they can be completed quickly. More experienced users may want to refer only to exercises detailing the use of specific instructions or features. Most exercises are "stand-alone" and can be completed individually. *However, some exercises assume that you've completed a previous exercise (such as exercises which delete or erase a previously saved format or graphic image).*

Be sure you know how to load supplies and set up the printer before you begin these exercises. If you haven't yet learned how to set up and load supplies into your printer, refer to the Operator Quick Reference or the Operator Guide.

You should ensure that labels of sufficient size (*at least 80mm wide and at least 60mm long for printers with 8 dot/mm print heads*) and (*at least 80mm wide and at least 90mm long for printers with 6 dot/mm print heads*) have been loaded before starting these exercises. You can use media of different sizes for these exercises, however you may need to modify Field Origins and other parameters affecting size or location of printed data.

You can also use continuous media for these exercises. If you do, you must set label length using the **^LL** instruction.

These exercises have been designed for Zebra printers controlled by IBM compatible personal computers, which are NOT part of a network. While ZPL II instructions use only standard ASCII characters and the printer may be controlled by mainframes, minicomputers or the Zebra-Mate data entry terminal we've chosen the personal computer for example purposes because of the relative familiarity with this type of host among users.

You can use any word processor or text editor capable of creating ASCII only files (without formatting codes and other extraneous information) to create the programs in these exercises (In WordStar™ you would open a NON-DOCUMENT file).

PROGRAMMING EXERCISES

In the first few exercises, {Return} is used to indicate where you should press the Return or Enter key to enter each line. Later exercises assume that the return key is pressed after each instruction line.

You should use factory default parameters except where indicated in specific exercises.

Note: The actual size of your printed examples may be different than those shown in the manual. The important thing is that they look the same.

Exercise #1 - Creating a Simple Label

This exercise is designed to guide you through the basic steps that are required to create most common labels that include text and a bar code.

This exercise uses the default parameter settings for both text and bar codes. Changing default values and using parameters is covered in Exercise 2 (Changing Text and Bar Code Parameters).

The ZPL II instructions you will use in this exercise are:

Format Bracket Instructions	(^XA, ^XZ)
Label Definition Instruction	(^LH)
Label Field Definition Instructions	(^FD, ^FO, ^FS)
Alphanumeric Field Instruction	(^AD)
Bar Code Field Instruction	(^B3)

Note: Only one of the many available bar codes was used in this exercise.

The ZPL II instructions sent to the printer are:

```
^XA
^LH30,30
^FO20,10^AD^FDZEBRA^FS
^FO20,60^B3^FDAAA001^FS
^XZ
```

PROGRAMMING EXERCISES

Exercise #1 - Programming Instructions

Type the instructions (**shown in bold**) in the order given. An explanation of what each instruction does is in brackets.

^XA{Return}

[^XA - Indicates start of label format.]

^LH30,30{Return}

[^LH - Sets label home position 30 dots to right and 30 dots down from top edge of label.]

^FO20,10^AD^FDZEBRA^FS{Return}

[^FO - Set field origin 20 dots to the right and 10 dots down from the HOME position defined with the ^LH instruction.]

[^AD - Select Font "D."]

[^FD - Start of field data.]

[ZEBRA - Actual field data.]

[^FS - End of field data.]

^FO20,60^B3^FDAAA001^FS{Return}

[^FO - Set field origin 20 dots to the right and 60 dots down from the Label Home Position.]

[^B3 - Select Code 39 bar code.]

[^FD - Start of field data for bar code.]

[AAA001 - Actual field data.]

[^FS - End of field data.]

^XZ{Return}

[^XZ - Indicates end of label format.]

Exercise #2 - Changing Text and Bar Code Parameters

This exercise covers the effects of changing text and bar code parameters. Text parameters are used to change field rotation, and to define the character height and width. Bar code parameters vary depending on the code selected.

The Code 39 bar code is used in this exercise. Only those parameters that apply to Code 39 bar codes are used. If you want to use a different bar code, refer to Section 5 regarding specific information on the various types of bar codes and their parameters.

The ZPL II instructions you will use in this exercise are:

Format Bracket Instructions	(^XA, ^XZ)
Label Definition Instruction	(^LH)
Label Field Definition Instructions	(^FD, ^FO, ^FS)
Alphanumeric Field Instruction	(^AD)
Bar Code Field Instruction	(^B3)

The ZPL II instructions sent to the printer are:

```
^XA  
^LH30,30  
^FO20,10^ADN,56,30^FDZEBRA^FS  
^FO20,80^B3N,Y,40,N,N^FDAAA001^FS  
^XZ
```

Exercise #2 - Programming Instructions

Type the instructions (**shown in bold**) in the order given. An explanation of what each instruction does is in brackets.

^XA{Return}

[^XA - Indicates start of label format.]

^LH30,30{Return}

[^LH - Sets label home position 30 dots to right and 30 dots down from top edge of label.]

^FO20,10^ADN,56,30^FDZEBRA^FS{Return}

[^FO - Set field origin 20 dots to the right and 10 dots down from the HOME position defined with the ^LH instruction.]

[^AD - Select Font "D" indicating (N)ormal rotation.

Select character height at 56 dots and character width at 30 dots.]

[^FD - Start of field data.]

[ZEBRA - Actual field data.]

[^FS - End of field data.]

^FO20,80^B3N,Y,40,N,N^FDAAA001^FS{Return}

[^FO - Set field origin 20 dots to the right and 80 dots down from the Label Home Position.]

[^B3 N,Y,40,N,N- Select Code 39 bar code. Calculate checkdigit. Set bar code height to 40 dots. Do not print interpretation line below bar code.]

[^FD - Start of field data for bar code.]

[AAA001 - Actual field data.]

[^FS - End of field data.]

^XZ{Return}

[^XZ - Indicates end of label format.]

PROGRAMMING EXERCISES

REVIEW

Save this file, name it "EXER2.ZPL" Copy the file to the printer. Compare your results with those shown below.

ZEBRA



If your label does not look like the one shown, confirm that the file you created is identical to the listing at the beginning of this exercise and repeat the printing procedure.

Exercise # 3 - Changing Default Text Parameters, Using International Character Sets, and Using Graphic Symbols

In this exercise you will learn how to modify default text parameters and how to select international character sets and graphic symbols

This exercise somewhat modifies Exercise #2. It includes setting default parameters for text fields, selecting an international character set and the use of a graphic symbol.

The ZPL II instructions you will use in this exercise are:

Format Bracket Instructions	(^XA, ^XZ)
Label Definition Instruction	(^LH)
Label Field Definition Instructions	(^FD, ^FO, ^FS)
Alphanumeric Field Instructions	(^CF, ^CI)
Graphic Symbol Instruction	(^GS)
Bar Code Field Instruction	(^B3)

The ZPL II instructions sent to the printer are:

```
^XA
^LH100,100
^CFF^CI7
^FO20,20^FD#ZEBRA@^FS
^FO140,22^GS,36,36^FDA^FS
^FO20,80^B3,,40,,^FDAAA001^FS
^XZ
```

Exercise #3 - Programming Instructions

Type the instructions (**shown in bold**) in the order given. An explanation of what each instruction does is in brackets.

^XA{Return}

[^XA - Indicates start of label format.]

^LH100,100{Return}

[^LH - Sets label home position 100 dots to right and 100 dots down from top edge of label.]

^CFF^CI7{Return}

[^CFF - Select font "F" as the default font.]

[^CI7 - Select international character set 7 (France 1).]

^FO20,10^FD#ZEBRA@^FS{Return}

[^FO - Set field origin relative to label home.

Note: Since no font is specified, ^CFF will control font.]

[^FD - Start of field data.]

[#ZEBRA@ - Actual field data.]

[^FS - End of field data.]

^FO140,22^GS,36,36^FDA^FS{Return}

[^FO - Set field origin relative to label home.]

[^GS - Select graphic symbol.

Note: Values for "b" and "c" must be entered when ^CF instruction is used.]

[^FDA - Select graphic symbol A (registered trademark).]

[^FS - End of field data.]

^FO20,80,^B3,,40,,^FDAAA001^FS{Return}

[^FO - Set field origin relative to label home.]

[^B3,,40,, - Select Code 39 bar code.]

[^FD - Start of field data for bar code.]

[AAA001 - Actual field data.]

[^FS - End of field data.]

^XZ{Return}

[^XZ - Indicates end of label format.]

REVIEW

Save this file, name it "EXER3.ZPL" Copy the file to the printer. Compare your results with those shown below.

£ZEBRAa ®



AAA001

If your label does not look like the one shown, confirm that the file you created is identical to the listing at the beginning of this exercise and repeat the printing procedure.

Exercise # 4 - Non-Printing Field and Field Rotation

Non-printing fields are commonly used to include comments as part of a ZPL II program. Programs employing extensive use of comments are easier to understand and easier to modify by an operator or programmer unfamiliar with the original program.

Rotated fields print vertically on the label. If a bar code field is printed in the rotated orientation, it is called a "ladder" bar code. Bar codes printed in the non-rotated or horizontal orientation are called "picket fence" bar codes.

There is a second simple program at the end of the main exercise to reset field rotation defaults to non-rotated. It is included to avoid conflicts with subsequent exercises.

The ZPL II instructions you will use in this exercise are:

Format Bracket Instructions	(^XA, ^XZ)
Label Definition Instruction	(^LH)
Non-Printing Comment Instruction	(^FX)
Field Rotation Instruction	(^FWR)
Label Field Definition Instructions	(^FD, ^FO, ^FS)
Alphanumeric Field Instruction	(^AF)
Bar Code Field Instruction	(^B3)

The ZPL II instructions sent to the printer are:

```
^XA
^LH30,30
^FXTHIS WILL NOT PRINT^FS
^FO120,60^FWR^AF^FDZEBRA^FS
^FO60,60^B3,,40,,^FDAAA001^FS
^XZ
^XA^FVN^XZ
```

Exercise #4 - Programming Instructions

Type the instructions (**shown in bold**) in the order given. An explanation of what each instruction does is in brackets.

^XA

[^XA - Indicates start of label format.]

^LH30,30

[^LH - Sets label home position 30 dots to right and 30 dots down from top edge of label.]

^FXTHIS WILL NOT PRINT

[^FX - Indicates a non-printing field.]
[THIS WILL NOT PRINT - Actual field data.]

^FO120,60^FWR^AF^FDZEBRA^FS

[^FO - Set field origin relative to label home.
[^FWR - Set field rotation to 90 degrees.]
[^AF - Select font "F."
[^FD - Start of field data.]
[ZEBRA- Actual field data.]
[^FS - End of field data.]

^FO60,60,^B3,,40,,^FDAAA001^FS

[^FO - Set field origin relative to label home.]
[^B3,,40,, - Select Code 39 bar code.
[^FD - Start of field data for bar code.]
[AAA001 - Actual field data.]
[^FS - End of field data.]

^XZ

[^XZ - Indicates end of label format.]

^XA^FWN^XZ

[A separate program to return the rotation back to normal.]

PROGRAMMING EXERCISES

REVIEW

Save this file, name it "EXER4.ZPL" Copy the file to the printer. Compare your results with those shown below.



If your label does not look like the one shown, confirm that the file you created is identical to the listing at the beginning of this exercise and repeat the printing procedure.

**Exercise # 5- Line and Box Graphics,
Reverse Printing Fields**

This exercise discusses how to integrate simple box and/or line graphics with the label format created in prior exercises. Also discussed is the use of boxes in the creation of reverse printing fields using the field reverse instruction.

The ZPL II instructions you will use in this exercise are:

Format Bracket Instructions	(^XA, ^XZ)
Label Definition Instruction	(^LH)
Graphic Box Instruction	(^GB)
Reverse Printing Instruction	(^FR)
Label Field Definition Instructions	(^FD, ^FO, ^FS)
Alphanumeric Font Instruction	(^AF)
Bar Code Field Instruction	(^B3)

The ZPL II instructions sent to the printer are:

^XA
^LH30,30
^FO10,10^GB150,40,40^FS
^FO50,18^AF^FR^FDZEBRA^FS
^FO10,80^B3,,40,,^FDAAA001^FS
^FO10,160^GB150,100,4^FS
^XZ

PROGRAMMING EXERCISES

Exercise #5 - Programming Instructions

Type the instructions (**shown in bold**) in the order given. An explanation of what each instruction does is in brackets.

^XA

[^XA - Indicates start of label format.]

^LH30,30^FS

[^LH - Sets label home position 30 dots to right and 30 dots down from top edge of label.]

^FO10,10^GB150,40,40^FS

[^FO - Set field origin relative to label home.]

[^GB - Create a graphic box 150 dots wide, 40 dots high, using a line 40 dots thick. If thickness (the third parameter) equals either box length (the first parameter) or height (the second parameter), a solid (filled) box is produced.

[^FS - End of field data.]

^FO50,18^AF^FR^FDZEBRA^FS

[^FO - Set field origin relative to label home.]

[^AF - Select font "F."]

[^FR - Indicates that this field is printed in reverse (ie. white characters on a black background). The ^FR instruction MUST immediately precede the ^FD instruction indicating the start of field data. The box created with the preceding line creates the black background required for reverse printing of this field.]

[^FD - Start of field data.]

[ZEBRA- Actual field data.]

[^FS - End of field data.]

^FO10,80,^B3,,40,,^FDAAA001^FS

[^FO - Set field origin relative to label home.]

[^B3,,40,, - Select Code 39 bar code.

[^FD - Start of field data for bar code.]

[AAA001 - Actual field data.]

[^FS - End of field data.]

Instructions continued on next page

PROGRAMMING EXERCISES

^FO10,160^GB150,100,4^FS

[^FO - Set field origin relative to label home.]

[^GB - Create a graphic box 150 dots wide, 100 dots
high, using a line width of 4 dots. This box is NOT
filled.]

[^FS - End of field data.]

^XZ

[^XZ - Indicates end of label format.]

PROGRAMMING EXERCISES

REVIEW

Save this file, name it "EXER5.ZPL" Copy the file to the printer. Compare your results with those shown below.

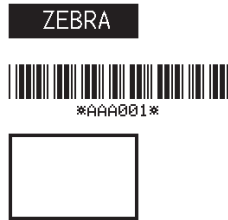

If your label does not look like the one shown, confirm that the file you created is identical to the listing at the beginning of this exercise and repeat the printing procedure.

Exercise # 6 - Saving Label Formats as Graphic Images

This exercise discusses how to save a label format as a graphic image and then recall (load) a label format that has been previously saved for printing. The exercise consists of two programs. The first contains a label format and the instructions necessary to save and print the format as a graphic image. The second program recalls and prints the label format that was saved as a graphic image using the first program.

While this exercise utilizes the **^IL** instruction to load a graphic image, the **^IM** instruction may also be used. These two instructions differ in that images loaded using the **^IL** instruction may be positioned using the **^FO** (field origin) instruction while **^IM** moves the complete image to memory and does not allow repositioning.

The ZPL II instructions you will use in this exercise are:

- Format Bracket Instructions (^XA, ^XZ)
- Label Definition Instruction (^LH)
- Label Field Definition Instructions (^FD, ^FO, ^FS)
- Alphanumeric Font Instruction (^AF)
- Bar Code Field Instruction (^B3)
- Image Save & Image Load Instructions (^IS, IL)

The ZPL II instructions sent to the printer are:

```

^XA
^LH30,30
^FO20,10^AFN,56,30^FR^FDZEBRA^FS
^FO20,80^B3N,Y,20,N,N^FDAAA001^FS
^FO10,160^GB150,100,4^FS
^ISEXERPROG,N
^XZ
^XA^ILEXERPROG^XZ
    
```

PROGRAMMING EXERCISES

Exercise #6 - Programming Instructions

Type the instructions (**shown in bold**) in the order given. An explanation of what each instruction does is in brackets.

^XA

[^XA - Indicates start of label format.]

^LH30,30

[^LH - Sets label home position 30 dots to right and 30 dots down from top edge of label.]

^FO20,10^AFN,56,30^FDZEBRA^FS

[^FO - Set field origin relative to label home.]

[^FWR - Set field rotation to 90 degrees.]

[^AF - Select font "F."]

[^FD - Start of field data.]

[ZEBRA- Actual field data.]

[^FS - End of field data.]

^FO20,80,^B3N,Y,20,N,N^FDAAA001^FS

[^FO - Set field origin relative to label home.]

[^B3N,Y,20,N,N - Select Code 39 bar code. Calculate check digit, do not print interpretation line.]

[^FD - Start of field data for bar code.]

[AAA001 - Actual field data.]

[^FS - End of field data.]

^ISEXERPROG,N

[^IS - Save format as a graphic image named "EXERPROG," do not print after saving.]

^XZ

[^XZ - Indicates end of label format.]

^XA^ILEXERPROG^XZ

[^XA - Start of label format.]

[^ILEXERPROG,N - Load and print the graphic image saved as "EXERPROG."]

[^XZ - End of label format.]

REVIEW

Save this file, name it “EXER6.ZPL” Copy the file to the printer. Compare your results with those shown below.

ZEBRA



If your label does not look like the one shown, confirm that the file you created is identical to the listing at the beginning of this exercise and repeat the printing procedure.

Exercise # 7 - Downloading and Printing Graphic Images

This exercise discusses how to include a hexadecimal graphic image as part of your label.

In order to store graphic images, sufficient memory must be allocated (reserved) for them. Memory for storing graphic images is allocated “on the fly” as needed. The graphic images can then be recalled and integrated with additional label data without downloading the entire image each time a label is printed. Graphic Images are downloaded using the **~DG** instruction along with appropriate parameters to indicate the size of the graphic being downloaded.

Graphic images may be created using a drawing or painting program which creates files in the .PCX format. These files must then be converted to ZPL II format (pure hexadecimal data without headers or other extraneous information which may be attached to the data by the draw or paint program used) for use as part of a label format. Hexadecimal data may also be directly input as part of a ZPL II program as shown in this exercise.

The **~DG** instruction requires parameters indicating the size of the graphic image. The format for this instruction is:

~DGname (8 characters, upper case ASCII),
total number of bytes in graphic (5 digits),
number of bytes per row (3 digits),
hexadecimal data.

Refer to Section 6 for detailed instructions on calculating the total number of bytes and the number of bytes per row. The data included with this exercise produces a simple checkerboard pattern.

ZPL II instructions begin on the next page.

PROGRAMMING EXERCISES

The ZPL II instructions you will use in this exercise are:

Format Bracket Instructions	(^XA, ^XZ)
Download Graphic Instruction	(~DG)
Recall Graphic Instructions	(^XG)

The ZPL II instructions sent to the printer are:

```
~DGCHECKERS,00400,010,  
0000FFFF0000FFFF0000  
0000FFFF0000FFFF0000  
0000FFFF0000FFFF0000  
0000FFFF0000FFFF0000  
FFFF0000FFFF0000FFFF  
FFFF0000FFFF0000FFFF  
FFFF0000FFFF0000FFFF  
FFFF0000FFFF0000FFFF  
0000FFFF0000FFFF0000  
0000FFFF0000FFFF0000  
0000FFFF0000FFFF0000  
0000FFFF0000FFFF0000  
0000FFFF0000FFFF0000  
FFFF0000FFFF0000FFFF  
FFFF0000FFFF0000FFFF  
FFFF0000FFFF0000FFFF  
FFFF0000FFFF0000FFFF  
FFFF0000FFFF0000FFFF  
0000FFFF0000FFFF0000  
0000FFFF0000FFFF0000  
0000FFFF0000FFFF0000  
0000FFFF0000FFFF0000
```

Instructions are continued on the next page.

PROGRAMMING EXERCISES

```
FFFF0000FFFF0000FFFF
FFFF0000FFFF0000FFFF
FFFF0000FFFF0000FFFF
FFFF0000FFFF0000FFFF
0000FFFF0000FFFF0000
0000FFFF0000FFFF0000
0000FFFF0000FFFF0000
0000FFFF0000FFFF0000
FFFF0000FFFF0000FFFF
FFFF0000FFFF0000FFFF
FFFF0000FFFF0000FFFF
FFFF0000FFFF0000FFFF
```

```
^XA
^FO50,50^XGCHECKERS,3,2^FS
^XZ
```

```
^XA
^FO50,50^XGCHECKERS,5,1^FS
^XZ
```

Exercise #7 - Programming Instructions

Type the instructions (**shown in bold**) in the order given. An explanation of what each instruction does is in brackets.

~DGCHECKERS,00400,010,

[^DG - Set printer to graphics mode and name graphic to be downloaded "CHECKERS."]

[00400,010 - Set number of bytes to be downloaded to 400, set bytes per row to Ten(10).

0000FFFF0000FFFF0000

0000FFFF0000FFFF0000

0000FFFF0000FFFF0000

0000FFFF0000FFFF0000

FFFF0000FFFF0000FFFF

FFFF0000FFFF0000FFFF

FFFF0000FFFF0000FFFF

FFFF0000FFFF0000FFFF

(Above sequence repeated four (4) more times.)

^XA^FO50,50^XGCHECKERS,3,2^XZ

[^XA - Start of label format.]

[^FO - Set field origin relative to label home.]

[^XGCHECKERS,3,2 - Recall graphic image named "CHECKERS." Magnify by a factor of 3 along x axis and 2 along y axis.]

[^XZ - End of label format.]

^XA^FO50,50^XGCHECKERS,5,1^XZ

[^XA - Start of label format.]

[^FO - Set field origin relative to label home.]

[^XGCHECKERS,5,1 - Recall graphic image named "CHECKERS." Magnify by a factor of 5 along x axis and 1 along y axis.]

[^XZ - End of label format.]

PROGRAMMING EXERCISES

REVIEW

Save this file, name it "EXER7.ZPL" Copy the file to the printer. Compare your results with those shown below.



If your label does not look like the one shown, confirm that the file you created is identical to the listing at the beginning of this exercise and repeat the printing procedure.

Exercise # 8 - Deleting Graphic Images

For the remainder of these exercises, only the instructions actually sent to the printer will be shown.

This exercise discusses how to delete a graphic image. Graphic images may be deleted from printer memory using either the **^ID** instruction which is used to delete a specific graphic image stored in memory or the **^EG** instruction which erases ALL graphic images stored in memory.

Note: A **~EG** instruction sent to the printer will also delete ALL images stored in memory.

This exercise will erase the graphic image named “CHECKERS” which was previously stored in Exercise #7.

The ZPL II instructions sent to the printer are:

`^XA`

`^IDCHECKERS`

`^XZ`

`^XA`

`^FO50,50^XGCHECKERS`

`^FO50,90^AF^FDLOOK NO CHECKERS^FS`

`^XZ`

PROGRAMMING EXERCISES

Exercise #8 - Programming Instructions

Type the instructions (**shown in bold**) in the order given. An explanation of what each instruction does is in brackets.

^XA

[^XA - Indicates start of label format.]

^ID CHECKERS

[^ID - Delete the image called CHECKERS from memory.]

^XZ

[^XZ - Indicates end of label format.]

^XA

[^XA - Indicates start of label format.]

^FO50,50^XGCHECKERS

[This line attempts to call the graphic image that was just deleted. If the deletion was successful, only the following line will print.]

^FO50,90^AF^FDLOOK NO CHECKERS^FS

[^FO - Set field origin relative to label home.

[^AF - Select font "F."]

[^FD - Start of field data.]

[LOOK NO CHECKERS - Actual field data.]

[^FS - End of field data.]

^XZ

[^XZ - Indicates end of label format.]

PROGRAMMING EXERCISES

REVIEW

Save this file, name it “EXER8.ZPL” Copy the file to the printer. Compare your results with those shown below.

LOOK NO CHECKERS

If your label does not look like the one shown, confirm that the file you created is identical to the listing at the beginning of this exercise and repeat the printing procedure.

PROGRAMMING EXERCISES

Exercise # 9 - Printing Quantities of Labels, Printing Entire Label in Inverted Orientation, Setting the Print Rate and Suppressing Backfeed

This exercise discusses how to set the print speed, print a predetermined quantity of labels, suppress backfeed for tear-off and print entire labels in an inverted orientation.

The ZPL II instructions sent to the printer are:

`^XA^PRB^XZ`

`^XA`

`^LH360,30`

`^FO20,10^AF^FDZEBRA^FS`

`^FO20,60^B3^FDAAA001^FS`

`^POI`

`^PQ2`

`^XB`

`^XZ`

Exercise #9 - Programming Instructions

Type the instructions (**shown in bold**) in the order given. An explanation of what each instruction does is in brackets.

^XA^PRB^XZ

[^XA - Indicates start of label format.]

[^PRB - Set print rate to speed "B." (3 inches/second)]

[^XZ - End of ZPL program.]

^XA

^LH360,30

^FO20,10^AF^FDZEBRA^FS

^FO20,20,^B3^FDAAA001^FS

[This portion of the program is the sample label format presented in Exercise #1. Field origins have been adjusted for inverted orientation.]

^POI

[^POI - Set print orientation to Invert the entire label.]

^PQ2

[^PQ2 - Set print quantity to print 2 labels.]

^XB

[^XB - Suppress Backfeed for tear-off modes.]

^XZ

[^XZ - Indicates end of label format.]

PROGRAMMING EXERCISES

REVIEW

Save this file, name it "EXER9.ZPL" Copy the file to the printer. Compare your results with those shown below.



If your labels do not look like the ones shown, confirm that the file you created is identical to the listing at the beginning of this exercise and repeat the printing procedure.

**Exercise # 10 - Slew Instruction, Form Feed Instruction
and Printing Entire Formats in Reverse**

This exercise discusses the slew and form feed (slew to home) instructions and the instructions required for printing the entire label in reverse.

The ZPL II instructions sent to the printer are:

^XA

^PRA

^LRY

^LH30,30

^FO0,0^GB400,300,300^FS

^FO20,10^AF^FDZEBRA^FS

^FO20,60^B3,,40,,^FDAAA001^FS

^PF50

^FO20,160^AF^FDSLEW EXAMPLE^FS

^XZ

^XA^PH^XZ

^XA

^FO20,10^AF^FDZEBRA^FS

^FO20,60^B3,,40,,^FDAAA001^FS

^PF50

^FO20,160^AF^FDSLEW EXAMPLE^FS

^XZ

PROGRAMMING EXERCISES

Exercise #10 - Programming Instructions

Type the instructions (**shown in bold**) in the order given. An explanation of what each instruction does is in brackets.

^XA

[^XA - Indicates start of label format.]

^PRA

[^PRA - Set print rate to speed "A." (2 inches/second)]

^LRY

[^LRY - Reverse print entire label.]

^LH30,30

[^LH - Sets label home position 30 dots to right and 30 dots down from top edge of label.]

^FO0,0^GB400,300,300^FS

[^FO - Set field origin relative to label home.]

[^GB - Create a filled graphic box to be used as background for reverse printed label. (May need to adjust parameters for different media size.)

^FO20,10^AF^FDZEBRA^FS

[^FO - Set field origin relative to label home.]

[^AF - Select font "F."]

[^FD - Start of field data.]

[ZEBRA- Actual field data.]

[^FS - End of field data.]

^FO20,60^B3,,40,,^FDAAA001^FS

[^FO - Set field origin relative to label home.]

[^B3 - Select Code 39 bar code.]

[^FD - Start of field data for bar code.]

[AAA001 - Actual field data.]

[^FS - End of field data.]

^PF50

[Slew 50 dot rows at bottom of label.]

Instructions continued on next page.

^FO20,160^AF^FDSLEW EXAMPLE^FS

[^FO - Set field origin relative to label home.]
[^AF - Select font "F."
[^FD - Start of field data.]
[SLEW EXAMPLE - Actual field data.]
[^FS - End of field data.]

^XZ

[^XZ - Indicates end of format.]

^XA^PH^XZ

[Instructions to feed to next home position.]

^XA

[^XA - Indicates start of format.]

^FO20,10^AF^FDZEBRA^FS

[^FO - Set field origin relative to label home.]
[^AF - Select font "F."
[^FD - Start of field data.]
[ZEBRA- Actual field data.]
[^FS - End of field data.]

^FO20,60^B3,,40,,^FDAAA001^FS

[^FO - Set field origin relative to label home.]
[^B3 - Select Code 39 bar code.]
[^FD - Start of field data for bar code.]
[AAA001 - Actual field data.]
[^FS - End of field data.]

^PF250

[^PF250 - Slew 250 dot rows.]

^FO20,160^AF^FDSLEW EXAMPLE^FS

[^FO - Set field origin relative to label home.]
[^AF - Select font "F."
[^FD - Start of field data.]
[SLEW EXAMPLE - Actual field data.]
[^FS - End of field data.]

^XZ

[^XZ - Indicates end of format.]

PROGRAMMING EXERCISES

REVIEW

Save this file, name it “EXER10.ZPL” Copy the file to the printer. Compare your results with those shown below.



ZEBRA



SLEW EXAMPLE

If your label does not look like the one shown, confirm that the file you created is identical to the listing at the beginning of this exercise and repeat the printing procedure.

Exercise # 11 - Using Serialized Fields

This exercise discusses the instructions and parameters required to produce serialized fields as part of a label format.

The ZPL II instructions sent to the printer are:

^XA

^LH30,30

^FO20,10^AF^FDZEBRA^FS

^FO20,60^B3,,40,,^FDAAA001^FS

^FO20,180^AF^SNSERIAL NUMBER 00000000111,1,Y^FS

^PQ10

^XZ

PROGRAMMING EXERCISES

Exercise #11 - Programming Instructions

Type the instructions (**shown in bold**) in the order given. An explanation of what each instruction does is in brackets.

^XA

[^XA - Indicates start of label format.]

^LH30,30

[^LH - Sets label home position 30 dots to right and 30 dots down from top edge of label.]

^FO20,10^AF^FDZEBRA^FS

[^FO - Set field origin relative to label home.]

[^AF - Select font "F."]

[^FD - Start of field data.]

[ZEBRA- Actual field data.]

[^FS - End of field data.]

^FO20,60^B3,,40,,^FDAAA001^FS

[^FO - Set field origin relative to label home.]

[^B3 - Select Code 39 bar code.]

[^FD - Start of field data for bar code.]

[AAA001 - Actual field data.]

[^FS - End of field data.]

^FO20,180^AF^SNSERIAL NUMBER 00000000111,1,Y^FS

[^FO - Set field origin relative to label home.]

[^AF^SNSERIAL NUMBER 00000000111,1,Y- Define serialized field, starting value of 111, increment by 1, insert leading zeros.]

[^FS - End of field data.]

^PQ10

[^PQ10 - Set print quantity to 10.]

^XZ

[^XZ- Indicates end of format.]

PROGRAMMING EXERCISES

REVIEW

Save this file, name it “EXER11.ZPL” Copy the file to the printer. Compare your results with those shown below.

ZEBRA



SERIAL NUMBER 00000000111

ZEBRA



SERIAL NUMBER 00000000120

A total of 10 labels should be printed. The first and last labels are shown here. If your labels do not look like the ones shown, confirm that the file you created is identical to the listing at the beginning of this exercise and repeat the printing procedure.

Exercise # 12 - Stored Formats

This exercise discusses the instructions and parameters required to use stored formats.

The ZPL II instructions sent to the printer are:

^XA

^DFFORMAT^FS

^LH30,30

^FO20,10^AF^FN1^FS

^FO20,60^B3,,40,,^FN2^FS

^XZ

^XA

^XFFORMAT

^FN1^FDZEBRA^FS

^FN2^FDAAA001^FS

^XZ

^XA

^XFFORMAT

^FN1^FDBEARS^FS

^FN2^FDZZZ999^FS

^XZ

Exercise #12 - Programming Instructions

Type the instructions (**shown in bold**) in the order given. An explanation of what each instruction does is in brackets.

^XA

[^XA - Indicates start of label format.]

^DFFORMAT^FS

[^DF - Download and store format.]

[FORMAT - Name of format.]

[^FS - End of field data.]

^LH30,30

[^LH - Sets label home position 30 dots to right and 30 dots down from top edge of label.]

^FO20,10^AF^FN1^FS

[^FO - Set field origin relative to label home.]

[^AF - Select font "F."]

[^FN1 - Assign field number 1.]

[^FS - End of field data.]

^FO20,60^B3,,40,,^FN2^FS

[^FO - Set field origin relative to label home.]

[^B3 - Select Code 39 bar code.]

[^FN2 - Assign field number 2.]

[^FS - End of field data.]

^XZ

[^XZ- Indicates end of format.]

^XA

[^XA - Indicates start of label format.]

^XFFORMAT^FS

[^XF - Recall stored format.]

[FORMAT - Name of format to be recalled.]

[^FS - End of field data.]

^FN1^FDZEBRA^FS

[^FN1 - Indicate following data should be inserted in area allocated for field number 1.]

[^FD - Indicate start of field data.]

[ZEBRA - Field data.]

[^FS - End of field data.]

Instructions continued on next page.

PROGRAMMING EXERCISES

^FN2^FDAAA001^FS

[^FN2 - Indicate following data should be inserted
in area allocated for field number 2.]
[^FD - Indicates start of field data.]
[AAA001 - Field data.]
[^FS - End of field data.]

^XZ

[^XZ- Indicates end of format.]

^XA

[^XA - Indicates start of label format.]

^XFFORMAT^FS

[^XF - Recall stored format.]
[FORMAT - Name of format to be recalled.]
[^FS - End of field data.]

^FN1^FDBEARS^FS

[^FN1 - Indicates following data should be inserted
in area allocated for field number 1.]
[^FD - Indicates start of field data.]
[BEARS - Field data.]
[^FS - End of field data.]

^FN2^FDZZZ999^FS

[^FN2 - Indicates following data should be inserted
in area allocated for field number 2.]
[^FD - Indicates start of field data.]
[ZZZ999 - Field data.]
[^FS - End of field data.]

^XZ

[^XZ- Indicates end of format.]

PROGRAMMING EXERCISES

REVIEW

Save this file, name it “EXER12.ZPL” Copy the file to the printer. Compare your results with those shown below.

ZEBRA



BEARS



If your labels do not look like the ones shown, confirm that the file you created is identical to the listing at the beginning of this exercise and repeat the printing procedure.

Exercise # 13 - Erasing Stored Formats

This exercise discusses the instructions required to erase any stored formats saved in the printer memory.

The ZPL II instructions sent to the printer are:

^XA

^EF^FS

^XZ

^XA

^XFFORMAT

^FN1^FDBEARS^FS

^FN2^FDZZZ999^FS

^FO30,30^CFF^FDNO FORMAT TO RECALL^FS

^XZ

Exercise #13 - Programming Instructions

Type the instructions (**shown in bold**) in the order given. An explanation of what each instruction does is in brackets.

^XA

[^XA - Indicates start of label format.]

^EF^FS

[^EF - Erase all previously stored formats.]

[^FS - End of field data.]

^XZ

[^XZ- Indicates end of format.]

^XFFORMAT^FS

[^XF - Recall stored format.]

[FORMAT - Name of format to be recalled.]

[^FS - End of field data.]

^FN1^FDBEARS^FS

[^FN1 - Indicates following data should be inserted
in area allocated for field number 1.]

[^FD - Indicates start of field data.]

[BEARS - Field data.]

[^FS - End of field data.]

^FN2^FDZZZ999^FS

[^FN2 - Indicates following data should be inserted
in area allocated for field number 2.]

[^FD - Indicates start of field data.]

[ZZZ999 - Field data.]

[^FS - End of field data.]

^FO30,30^CFF^FDNO FORMAT TO RECALL^FS

[^FO30,30 - Set field origin relative to label home.]

[^CFF - Change to font "F".]

[^FD - Indicates start of field data.]

[NO FORMAT TO RECALL - Field data.]

[^FS - End of field data.]

^XZ

[^XZ- Indicates end of format.]

PROGRAMMING EXERCISES

REVIEW

Save this file, name it “EXER13.ZPL” Copy the file to the printer. Compare your results with those shown below.

NO FORMAT TO RECALL

If your label does not look like the one shown, confirm that the file you created is identical to the listing at the beginning of this exercise and repeat the printing procedure.

Exercise # 14 - Using Variable Data Fields

This exercise discusses the instructions and parameters required to produce serialized fields as part of a label format.

The ZPL II instructions sent to the printer are:

^XA^MCY^XZ

^XA

^LH30,30

^FO20,10^AF^FVZEBRA^FS

^FO20,60^B3N,,100^FDAAA001^FS

^MCN

^XZ

^XA

^FO20,10^AF^FVCUBS^FS

^XZ

^XA

^FO20,10^AF^FVBULLS^FS

^XZ

^XA

^FO20,10^AF^FVBEARS^FS

^XZ

^XA^MCY^XZ

Exercise #14 - Programming Instructions

Type the instructions (**shown in bold**) in the order given. An explanation of what each instruction does is in brackets.

^XA^MCY^XZ

[^XA - Indicates start of label format.]

[^MCY - Clear Map]

[^XZ - End of format.]

^XA

[^XA - Indicates start of label format.]

^LH30,30

[^LH - Sets label home position 30 dots to right and 30 dots down from top edge of label.]

^FO20,10^AF^FVZEBRA^FS

[^FO - Set field origin relative to label home.]

[^AF - Select font "F."]

[^FV - Indicates start of VARIABLE field data.]

[ZEBRA - Variable data.]

[^FS - Indicates end of variable data field.]

^FO20,60^B3N,,100^FDAAA001^FS

[^FO - Set field origin relative to label home.]

[^B3 - Select Code 39 bar code.]

[^FD - Start of field data for bar code.]

[AAA001 - Actual field data.]

[^FS - End of field data.]

^MCN

[^MCN - Set Map Clear to N=No.]

^XZ

[^XZ - End of format.]

Instructions continued on next page.

^XA

[^XA - Indicates start of label format.]

^FO20,10^AF^FVCUBS^FS

[^FO - Set field origin relative to label home.]

[^AF - Select font "F."]

[^FV - Indicates start of VARIABLE field data.]

[CUBS- Variable data.]

[^FS - Indicates end of variable data field.]

^XZ

[^XZ - End of format.]

^XA

[^XA - Indicates start of label format.]

^FO20,10^AF^FVBULLS^FS

[^FO - Set field origin relative to label home.]

[^AF - Select font "F."]

[^FV - Indicates start of VARIABLE field data.]

[BULLS - Variable data.]

[^FS - Indicates end of variable data field.]

^XZ

[^XZ - End of format.]

^XA

[^XA - Indicates start of label format.]

^FO20,10^AF^FVBEARS^FS

[^FO - Set field origin relative to label home.]

[^AF - Select font "F."]

[^FV - Indicates start of VARIABLE field data.]

[BEARS - Variable data.]

[^FS - Indicates end of variable data field.]

^XZ

[^XZ - End of format.]

^XA^MCY^XZ

[^XA - Indicates start of label format.]

[^MCY - Clear Map]

[^XZ - End of format.]

PROGRAMMING EXERCISES

REVIEW

Save this file, name it "EXER14.ZPL" Copy the file to the printer. Compare your results with those shown below.

ZEBRA



CUBS



BULLS



BEARS



A total of 4 labels should be printed. They are shown here. If your labels do not look like the one shown, confirm that the file you created is identical to the listing at the beginning of this exercise and repeat the printing procedure.

Appendix A - ASCII Code Chart

The following page contains a chart of the ASCII (American Standard Code for Information Interchnage) Code used by this Zebra printer.

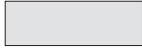

Those characters on the chart that are filled in like the box shown here are NOT recommended for use as a Command Prefix, Format Prefix or Delimiter Character.

APPENDIX A

HEX	CHAR	HEX	CHAR	HEX	CHAR	HEX	CHAR
00	NUL	20	space	40	@	60	'
01	SOH	21	!	41	A	61	a
02	STX	22	"	42	B	62	b
03	ETX	23	#	43	C	63	c
04	EOT	24	\$	44	D	64	d
05	ENQ	25	%	45	E	65	e
06	ACK	26	&	46	F	66	f
07	BEL	27	'	47	G	67	g
08	BS	28	(48	H	68	h
09	HT	29)	49	I	69	i
0A	LF	2A	*	4A	J	6A	j
0B	VT	2B	++	4B	K	6B	k
0C	FF	2C	,	4C	L	6C	l
0D	CR	2D	-	4D	M	6D	m
0E	SO	2E	.	4E	N	6E	n
0F	SI	2F	/	4F	O	6F	o
10	DLE	30	0	50	P	70	p
11	DC1	31	1	51	Q	71	q
12	DC2	32	2	52	R	72	r
13	DC3	33	3	53	S	73	s
14	DC4	34	4	54	T	74	t
15	NAK	35	5	55	U	75	u
16	SYN	36	6	56	V	76	v
17	ETB	37	7	57	W	77	w
18	CAN	38	8	58	X	78	x
19	EM	39	9	59	Y	79	y
1A	SUB	3A	:	5A	Z	7A	z
1B	ESC	3B	;	5B	[7B	{
1C	FS	3C	<	5C	\	7C	
1D	GS	3D	=	5D]	7D	}
1E	RS	3E	>	5E	^^	7E	~
1F	US	3F	?	5F	_	7F	DEL

Appendix B - Mod 10 Check Digit

The calculations for determining the Mod 10 Check Digit character are as follows:

1. Starting from position 1 of the number (left hand digit), the values in the even number positions are added together.

$$0 + 2 + 4 + 6 + 8 + 0 = 20$$

2. The result of Step 1 is multiplied by 3.

$$20 \times 3 = 60$$

3. Starting from position 2 of the number, the values in the odd number positions are added together.

$$1 + 3 + 5 + 7 + 9 = 25$$

4. The results of steps 1 and 3 are added together.

$$60 + 25 = 85$$

5. The check character (12th character) is the smallest number which when added to the result in step 4, produces a multiple of 10.

$$85 + X = 90 \text{ (next higher multiple of 10)}$$

$$X = 5 \text{ Check Character}$$

The following is a bar code that illustrates the above example. The digit on the right ("5") is the check digit.



THIS PAGE INTENTIONALLY LEFT BLANK

Appendix C - Mod 43 Check Digit

The calculations for determining the Mod 43 Check Digit character are as follows:

Each character in the Code 39 Character set has a specific value. These are shown in the chart below.

0=0	B=11	M=22	X=33
1=1	C=12	N=23	Y=34
2=2	D=13	O=24	Z=35
3=3	E=14	P=25	- =36
4=4	F=15	Q=26	. = 37
5=5	G=16	R=27	Space=38
6=6	H=17	S=28	\$=39
7=7	I=18	T=29	/=40
8=8	J=19	U=30	+ =41
9=9	K=20	V=31	% =42
A=10	L=21	W=32	

Sample Data String: **12345ABCDE/**

1. Add the sum of all the character values in the data string. Using the Chart above, the sum of the character values is as follows:

$$1 + 2 + 3 + 4 + 5 + 10 + 11 + 12 + 13 + 14 + 40 = 115$$

2. Divide the total by 43. Keep track of the remainder.
115/43 = 2 Remainder is 29

APPENDIX C

3. The “check digit” is the character that corresponds to the value of the remainder.

Remainder = 29.

29 is the value for the letter T.

T is the check digit.

The following is a bar code that illustrates the above example. The digit on the right (“T”) is the check digit.



^F0125,100^B3N,Y,150,Y,N^FD12345ABCDE/^FS

Appendix D - Host Status Return

When the Printer Status Command, ~HS, is sent to the Zebra printer, three data strings are sent back to the Host. Each string starts with an <STX> Control Code and is terminated by an <ETX><CR><LF> Control Code sequence. In this way, to avoid confusion, each String will be displayed/printed on a separate line by the Host.

String 1

<STX>aaa,b,c,dddd,eee,f,g,h,iii,j,k,l<ETX><CR><LF>

- aaa = Communication (Interface) Settings (*)
- b = "Paper Out" Flag (1=Paper Out)
- c = "Pause" Flag (1=Pause Active)
- dddd = Label Length (Value in Number of Dots)
- eee = Number of Formats in Receive Buffer
- f = "Buffer Full" Flag (1=Receive Buffer Full)
- g = "Communications Diagnostic Mode" Flag
(1= Diagnostic Mode Active)
- h = "Partial Format" Flag (1=Partial Format in Progress)
- iii = UNUSED (Always 000)
- j = "Corrupt RAM" Flag (1=Configuration Data Lost)
- k = Temperature Range (1 = Under Temperature)
- l = Temperature Range (1 = Over Temperature)

(*) This parameter specifies the Printer's baud rate, # of data bits, # of stop bits, parity setting and type of handshaking. This value is a 3-digit decimal representation of an eight-bit binary number. To evaluate this parameter, first convert the decimal number to a binary number. Then, the 9-digit binary number is read as follows:

$$aaa = a^8 a^7 a^6 a^5 a^4 a^3 a^2 a^1 a^0$$

a⁸ = High Speed Baud Rate

0 = 110 thru 19200 baud

1 = 28800 baud and above

a⁷ = Handshake

0 = Xon/Xoff

1 = DTR

Continued on the next page.

a⁶ = Parity Odd/Even

0 = Odd
1 = Even

a⁵ = Disable/Enable

0 = Disable
1 = Enable

a⁴ = Stop Bits

0 = 2 Bits
1 = 1 Bit

a³ = Data Bits

0 = 7 Bits
1 = 8 Bits

a⁸ a² a¹ a⁰ = Baud

0	0	0	0	= 110
0	0	0	1	= 300
0	0	1	0	= 600
0	0	1	1	= 1200
0	1	0	0	= 2400
0	1	0	1	= 4800
0	1	1	0	= 9600
0	1	1	1	= 19200
1	0	0	0	= 28800
1	0	0	1	= 38400 (not implemented)
1	0	1	0	= 57600

String 2

<STX>mmm,n,o,p,q,r,s,t,uuuu,v,www<ETX><CR><LF>

- mmm = Function Settings(*)
- n = 0 (Unused)
- o = "Head Up" Flag (1 = Head in UP Position)
- p = "Ribbon Out" Flag (1= Ribbon Out)
- q = "Thermal Transfer Mode" Flag (1 = Thermal Transfer Mode Selected)
- r = Print Mode
 - 0 = Rewind
 - 1=Peel Off
 - 2=Tear Off
 - 3=Reserved
- s = Print Width Mode
 - 6= 4.41"
- t = "Label Waiting" Flag (1=Label Waiting in Peel-Off Mode)
- uuuu = Labels remaining in Batch
- v = "Format While Printing" Flag (Always 1)
- www = Number of Graphic Images stored in Memory

(*) This parameter specifies the Printer's media type, sensor profile status, and communication diagnostics status. As in String 1, this is a 3-digit decimal representation of an eight-bit binary number. First, convert the decimal number to a binary number. Then, the 8-digit binary number is read as follows:

mmm = m7 m6 m5 m4 m3 m2 m1 m0

m7 = Media Type

- 0 = Die-Cut
- 1 = Continuous

m6= Sensor Profile

- 0 = Off
- 1 = On

m5= Communications Diagnostics

- 0 = Off
- 1 = On

Continued on the next page.

APPENDIX D

m4 m3 m2 m1 = Unused

0 = Always

m0 = Print Mode

0 = Direct Thermal

1 = Thermal Transfer

String 3

<STX>xxxx,y<ETX><CR><LF>

xxxx = 0000 (Reserved for future use)

y = 0 (Reserved for future use)

Appendix E - Memory Status Return

When the Memory Status Command, ~HM, is sent to the Zebra printer, a line of data containing three numbers is sent back to the Host. The information contained in that line is described here.

Memory Status Line

1024,0780,0780

First value is the *Total Amount of RAM* (Random Access Memory) installed in the printer. This number is in Kilobytes. In our example, the Zebra printer has 1024K RAM installed.

Second value is the *Maximum Amount of RAM* (Random Access Memory) available to the user. This number is in Kilobytes. In our example, the Zebra printer has a Maximum of 780K RAM available.

Third value is the amount of RAM (Random Access Memory) *currently available* to the user. This number is in Kilobytes. In our example, there is 780K of RAM in the Zebra printer currently available to the user.

NOTE 1: Memory taken up by Bit Maps *is not* excluded from the memory currently available value. (Due to ^MCN.)

NOTE 2: Downloading a graphic image or saving a bit map only affects the 3rd value. The 1st and 2nd values will not change after the printer is turned on.

THIS PAGE INTENTIONALLY LEFT BLANK

Appendix F - Code Page 850 Chart

CHR	HEX	DEC	CHR	HEX	DEC	CHR	HEX	DEC	CHR	HEX	DEC	CHR	HEX	DEC
	20	32	0	30	48	@	40	64	P	50	80	'	60	96
!	21	33	1	31	49	A	41	65	Q	51	81	a	61	97
"	22	34	2	32	50	B	42	66	R	52	82	b	62	98
#	23	35	3	33	51	C	43	67	S	53	83	c	63	99
\$	24	36	4	34	52	D	44	68	T	54	84	d	64	100
%	25	37	5	35	53	E	45	69	U	55	85	e	65	101
&	26	38	6	36	54	F	46	70	V	56	86	f	66	102
'	27	39	7	37	55	G	47	71	W	57	87	g	67	103
(28	40	8	38	56	H	48	72	X	58	88	h	68	104
)	29	41	9	39	57	I	49	73	Y	59	89	i	69	105
*	2a	42	:	3a	58	J	4a	74	Z	5a	90	j	6a	106
+	2b	43	;	3b	59	K	4b	75	[5b	91	k	6b	107
,	2c	44	<	3c	60	L	4c	76	ç	5c	92	l	6c	108
-	2d	45	=	3d	61	M	4d	77]	5d	93	m	6d	109
.	2e	46	>	3e	62	N	4e	78	^	5e	94	n	6e	110
/	2f	47	?	3f	63	O	4f	79	_	5f	95	o	6f	111

Appendix F

APPENDIX F

CHR	HEX	DEC	CHR	HEX	DEC	CHR	HEX	DEC	CHR	HEX	DEC	CHR	HEX	DEC
p	70	112	Ç	80	128	É	90	144	á	a0	160	⋮	b0	176
q	71	113	ü	81	129	æ	91	145	í	a1	161	⦿	b1	177
r	72	114	é	82	130	Æ	92	146	ó	a2	162	⦿	b2	178
s	73	115	â	83	131	ô	93	147	ú	a3	163		b3	179
t	74	116	ä	84	132	ö	94	148	ñ	a4	164	└	b4	180
u	75	117	à	85	133	ò	95	149	Ñ	a5	165	Á	b5	181
v	76	118	á	86	134	û	96	150	ª	a6	166	À	b6	182
w	77	119	ç	87	135	ù	97	151	º	a7	167	À	b7	183
x	78	120	ê	88	136	ÿ	98	152	¿	a8	168	©	b8	184
y	79	121	ë	89	137	ÿ	99	153	©	a9	169	≡	b9	185
z	7a	122	è	8a	138	Ü	9a	154	¬	aa	170		ba	186
{	7b	123	ï	8b	139	ø	9b	155	½	ab	171	└	bb	187
	7c	124	î	8c	140	£	9c	156	¼	ac	172	└	bc	188
}	7d	125	ì	8d	141	Ø	9d	157	í	ad	173	©	bd	189
~	7e	126	Ä	8e	142	×	9e	158	«	ae	174	¥	be	190
△	7f	127	Å	8f	143	ƒ	9f	159	»	af	175	└	bf	191

APPENDIX F

CHR	HEX	DEC	CHR	HEX	DEC	CHR	HEX	DEC	CHR	HEX	DEC
Ł	c0	192	Ō	d0	208	Ó	e0	224	.	f0	240
ł	c1	193	ō	d1	209	ó	e1	225	±	f1	241
Ł	c2	194	Ė	d2	210	ô	e2	226	=	f2	242
ł	c3	195	ė	d3	211	ò	e3	227	¾	f3	243
Ł	c4	196	Ě	d4	212	õ	e4	228	¶	f4	244
ł	c5	197	ě	d5	213	ō	e5	229	§	f5	245
ã	c6	198	í	d6	214	μ	e6	230	÷	f6	246
Ã	c7	199	î	d7	215	þ	e7	231	,	f7	247
Ł	c8	200	ï	d8	216	þ	e8	232	o	f8	248
ł	c9	201	Ĳ	d9	217	Ú	e9	233	”	f9	249
Ł	ca	202	Ĳ	da	218	ú	ea	234	.	fa	250
ł	cb	203	■	db	219	ù	eb	235	1	fb	251
Ł	cc	204	■	dc	220	ý	ec	236	3	fc	252
ł	cd	205	ı	dd	221	Ý	ed	237	2	fd	253
Ł	ce	206	İ	de	222	˘	ee	238	■	fe	254
ł	cf	207	■	df	223	’	ef	239		ff	255

THIS PAGE INTENTIONALLY LEFT BLANK

Appendix G - Error Detection Protocol

Introduction

There are many instances when it is vitally important that the information sent to the Zebra printer is received completely *Error-Free*. ZPL II supports an error detection protocol called Zebra Packet Response Protocol to meet this need.

Note: This protocol only works when using serial interface. IT DOES NOT FUNCTION WHEN USING PARALLEL INTERFACE.

What is a Protocol

A Protocol is a precisely defined set of rules. In the case of data communications, a Protocol defines how data is transmitted, received and acknowledged between two devices.

The sole purpose of the Packet Response Protocol is to ensure that the information sent from a Host computer to the Zebra printer is received accurately. *Remember, the protocol cannot insure the accuracy of the data that is actually sent from the Host computer.* The commands and data needed to make a label (ZPL II Format) are encapsulated within the information sent from the Host computer.

How Protocol Works

The basic unit of data transfer in the Packet Response Protocol is called a “Transaction.” A Transaction is a two-way communication procedure which consists of information being sent from the Host computer to the Zebra printer, and the printer sending back a response to the Host computer. This response is an indication that the Zebra printer has either accepted or rejected the information sent from the Host computer.

Information is sent in the form of “Packets.” Packets sent from the Host computer are called Request Packets.

When a Request Packet is received, the Zebra printer analyzes the information in the Packet. If the Request Packet is accepted, the Zebra printer will send a positive response back to the Host computer. The Host computer can then send the next Request Packet. If the information is rejected, the Zebra printer will send a negative response back to the Host computer. The Host computer then sends the same Request Packet again.

The Zebra Packet Response Protocol can be used in both single-printer applications, where there is only one Zebra printer connected to the Host computer, and multi-drop systems in which several Zebra printers are connected to the same Host computer.

Request Packet Formats (from the Host computer)

The first part of each data transfer Transaction is the sending of a Request Packet by the Host computer. The Request Packet contains a fixed length 'Header' block and a variable length "Data" block. Each Packet sent from the Host computer to the Zebra printer must always use the following format.

HEADER BLOCK					DATA BLOCK				
SOH	DST. Z-ID	SRC. Z-ID	TYPE	SEQ. #	STX	FORMAT	ETX	CRC	EOT
1	3	3	1	1	1	≤ 1024	1	2	1

The Request Packet Header Block is comprised of five fixed-length fields which are defined as follows.

SOH - (Start of Header Character) The Zebra printer interprets this character as the beginning of a new Request Packet. The ASCII Control Code character SOH (01H) is used as the Start of Header Character.

DST. Z-ID (Destination Zebra-ID) This is the three digit ASCII I.D. number used to identify which Zebra printer is to receive the Request Packet. The Zebra printer compares this number to the Network ID number assigned to it during Printer Configuration. The Zebra printer will act on the Request Packet only if these numbers match.

SRC. Z-ID (Source Zebra-ID) This is a three digit ASCII number used to identify the Host computer. This number is determined by the user.

TYPE (Packet Type) This field is used to define the type of Request Packet being sent by the Host. Only two characters are valid in this field.

‘P’ indicates a Print Request Packet

‘I’ indicates an Initialize Request Packet

Most of the Packets sent by the Host to the Zebra printer will be of the 'P' variety, requesting a label to be printed.

The 'I' character tells the Zebra printer to initialize the packet sequence numbering. It is required in the first packet of a new printing session, after starting up the Host computer or the Zebra printer.

SEQUENCE # (The Sequence Number of the Request Packet) This block contains a single digit number used to denote the current Transaction Number. The Host computer must increment this number by "1" for each new Request/Response Transaction pair, i.e. 0, 1, 2,..., 9. The numbers repeat after every 10 Transactions.

The Request Packet Data Block is comprised of four fixed-length fields and one variable-length field. These fields are defined as follows.

STX - (Start of Text) The Zebra printer interprets this character as the beginning of the variable-length Data Format portion of the Request Packet. The ASCII Control Code character STX (02H) is used as the Start of Text Character.

DATA FORMAT (Label Information) A variable-length portion of the Request Packet that contains the complete or partial ZPL II label format, or partial data string (such as a downloaded graphic).

This field can contain from 0 to 1024 characters. If the Format of a label is longer than 1024 characters, the Data Format fields from consecutive packets will be concatenated together in the printer's Receive Data Buffer as if they were sent as one long direct transmission.

Special consideration has been given to the possible requirement to include ASCII Control Characters (values less than 20H) in the Data Format portion of a Request Packet. Characters such as EOT (04H), STX (02H), SOH (01H), and ETX (03H), are part of the Error Detection Protocol and could interrupt normal communication procedures if received at the wrong time. *See DISGUISED CONTROL CODE CHARACTERS later in this description.*

ETX - (End of Text) The Zebra printer interprets this character as the end of the variable length Data Format portion of the Request Packet. The ASCII Control Code character ETX (03H) is used as the End of Text Character.

CRC - (Cyclic Redundancy Check) The CRC is a 2 character field. A Cyclic Redundancy Check is a type of error checking used to maintain the validity and integrity of the information transmitted between the Host computer and the Zebra printer. This Protocol uses the 16-bit CCITT method of producing a CRC.

The CRC is a two Byte value derived from the contents of the packet between, but not including, the SOH character and the CRC code itself. The Zebra printer will calculate a CRC of the Request Packet received and compare the value with the CRC Value in this field. The CRC of the Request Packet must match the CRC calculated by the Zebra printer in order for the Request Packet to be valid.

EOT - (End of Transmission) The Zebra printer interprets this character as the end of the Request Packet. The ASCII Control Code character EOT (04H) is used as the End of Transmission Character.

Response From the Zebra Printer

When the Zebra printer receives the EOT character, it will begin acting on the Request Packet received. The printer will compare certain characters and numeric values within the received Request Packet and send a response back to the Host computer.

Zebra Packet Response

The Packet Response protocol provides the highest degree of error checking and is well suited to the Host-Multiple Printer application. The Response Packet from the Zebra printer will always use the following format.

HEADER BLOCK					DATA BLOCK				
SOH	DST. Z-ID	SRC. Z-ID	TYPE	SEQ. #	STX	FORMAT	ETX	CRC	EOT
1	3	3	1	1	1	≤ 1024	1	2	1

The Response Packet Header Block is comprised of five fixed-length fields which are defined as follows.

SOH - (Start of Header Character) The Zebra printer sends this character as the beginning of a new Response Packet. The ASCII Control Code character SOH (01H) is used as the Start of Header Character.

DST. Z-ID (Destination Zebra-ID) This is the same three digit ASCII number used to identify the Host Computer that was contained in the SRC. Z-ID field of the Request Packet that initiated this Response Packet. The Host compares this number to its known value to insure it is the proper destination.

SRC. Z-ID (Source Zebra-ID) This is the three character ASCII Network I.D. of the Zebra printer that is sending the Response Packet.

TYPE (Packet Type) This block is used to define the type of Response Packet being sent to the Host. Only three characters are valid in this field.

- ‘A’ This is a Positive Acknowledgment to the Host computer. It indicates that the Request Packet was received without a CRC error. The Host computer may send the next Request Packet.
- ‘N’ This is the Negative Acknowledgment to the Host computer. It indicates that an error was detected in the packet sent from the Host computer. The Host computer must retransmit the same Request Packet again.
- ‘S’ This character indicates that the Response Packet contains the Zebra Printer Status requested by a ~HS (Host Status) instruction received from the Host.

SEQUENCE # (Used to denote the current message sequence number.) This number is identical to the message sequence number in the Request Packet. It denotes the message sequence number to which the Response Packet is replying.

The Response Packet Data Block is comprised of four fixed-length fields and one variable-length field. These fields are defined as follows.

STX - (Start of Text) The Zebra printer sends this character as the beginning of the variable length Data Format portion of the Response Packet. The ASCII Control Code character STX (02H) is used as the Start of Text Character.

DATA FORMAT (Label Information) The ‘variable length’ portion of the Response Packet. If the **Packet Type** field in the Response Header contains an ‘A’ or an ‘N’, no data will appear in this field. If the **Packet Type** field contains an ‘S’, this field will contain the Printer Status Message.

ETX - (End of Text) The Zebra printer sends this character as the end of the variable length Data Format portion of the Request Packet. The ASCII Control Code character ETX (03H) is used as the End of Text Character.

CRC - (Cyclic Redundancy Check) This is the CRC of the Response Packet as calculated by the Zebra printer. This Cyclic Redundancy Check maintains the validity and integrity of the information transmitted between the Zebra printer and the Host computer.

This CRC is a two Byte value derived from the contents of the packet between, but not including, the SOH character and the CRC code itself. The Host computer will calculate a CRC of the received Response Packet and compare it to the CRC value in this field. The CRC of the Response Packet must match the CRC calculated by the Host computer in order for the Response Packet to be valid.

EOT - (End of Transmission) The Zebra printer sends this character as the end of the Response Packet. The ASCII Control Code character EOT (04H) is used as the End of Transmission Character.

Disguising Control Code Characters

There may be occasions when ASCII Control Codes (00H - 19H) must be included as part of the Data Format block of a Request Packet. To eliminate any problems, these characters must be disguised so that the communication protocol does not act on them.

A three step procedure must be used to disguise each Control Code.

1. A SUB (1AH) character must precede each Control Code placed in the Data Format block.
2. The value of 40H must be added to the Hex value of the Control Code.
3. The ASCII Character corresponding to the total value produced in step 2 must be entered in the Data Format right after the SUB character.

The Zebra printer automatically converts the modified control character back to its correct value by discarding the SUB (1AH) character and subtracting 40H from the next character.

Example:

To include a DLE (10H) character in the Data Format block:

1. Enter a SUB (1AH) character into the Data Format.
2. Add 40H to the DLE value of 10H for a resulting value of 50H.
3. Enter the ASCII character “P” (50H) in the Data Format after the SUB character.

NOTE: This technique is counted as two characters of the 1024 allowed in the Data Format block.

Rules for Transactions

1. Every Transaction is independent of every other Transaction and can only be initiated by the Host computer.
2. A valid Response Packet must be received by the Host computer to complete a Transaction before the next Request Packet is sent.
3. If an error is encountered during a Transaction, the entire Transaction (i.e. Request Packet and Response Packet) must be repeated.
4. The Zebra printer does not provide for system time-outs and has no responsibility for insuring that its Response Packets are received by the Host computer.
5. The Host computer must provide time-outs for all of the Transactions and insure that communication continues.
6. If any part of a Transaction is lost or received incorrectly, it is the responsibility of the Host computer to retry the whole Transaction.

Error Detection Protocol Application

The following are the three basic requirements for setting up the Zebra printer to use the Error Detection Protocol.

Activating the Protocol

Protocol is a front panel selection.

Setting Up Communications

Insure that the Host computer and the Zebra printer are characterized with the same communication parameters, i.e. Parity, Baud Rate, etc.

Setting the Printer ID Number

The Protocol uses the printer's Network ID number to insure communication with the proper unit. The Network ID is programmed into the printer by sending the printer a **^NI** (Network ID Number) instruction.

If there is only one printer connected to the Host computer, the Network ID number should be set to all zeros (default).

If there is more than one printer, such as in a broadcast or multi-drop environment, each printer should be assigned its own unique ID number. Printers in this environment, with an ID of all zeros, will receive ALL label formats regardless of the actual printer ID number in the DST. Z-ID block of the Request Packet.

Error Conditions and System Faults

Restarting a Transmission

If a break in communication occurs, the Host must restart the transmission of the current label format with an Initialization Request Packet. The Zebra printer will not respond to Request Packets sent out of sequence. However, the Zebra printer **will respond** to an Initialization Request Packet and restart its internal counting with the sequence number of the Request Packet.

CRC Error Conditions and Responses

A CRC error condition can be detected when the printer receives a Request Packet or when the Host computer receives a Response Packet. The following list defines each of these errors and how the Host computer should respond to them.

1. **Error:** The CRC calculated by the Zebra printer does not match the one received as part of the Request Packet.
Response: The Zebra printer will return a Negative Acknowledgment Response Packet. The Host computer should retry the same Transaction with the same Sequence Number.

2. **Error:** The CRC calculated by the Host computer does not match the one received as part of the Response Packet.
Response: The Host computer should retry the same Transaction with the same Sequence Number.

Time-Out Error Conditions and Responses

There are certain conditions at the Zebra printer that might cause the Host computer to time-out while processing a Transaction. The following list illustrates these conditions and how the Host computer should respond to them.

- Error:** A Request Packet from the Host computer is not received by the Zebra printer.

Response: The Host computer times-out and resends the Request Packet of the same Transaction with the same Sequence Number.
- Error:** A Request Packet from the Host computer is partially received by the Zebra printer.

Response: The Host computer times-out and resends the Request Packet of the same Transaction with the same Sequence Number.
- Error:** A Response Packet from the Zebra printer is not received by the Host computer.

Response: The Host computer times-out and resends the Request Packet of the same Transaction with the same Sequence Number.
- Error:** A Response Packet from the Zebra printer is partially received by the Host computer.

Response: The Host computer times-out and resends the Request Packet of the same Transaction with the same Sequence Number.

How the Zebra Printer Processes a Request Packet

The following describes the steps taken at the Zebra printer to process a Request Packet.

1. The Zebra printer looks for an SOH (Start of Header) character. As soon as it finds one, it places the SOH and all the data after it into its Receive Data Buffer. This process continues until the printer receives an EOT (End of Transmission) character.

Note: If a second SOH is received *before* an EOT is detected, the contents of the Receive Buffer will be discarded. All of the data after the second SOH will be placed in the Receive Data Buffer.

2. After detecting the EOT, the printer checks for the following:
 - * The DST. Z-ID matches the printer's Network I.D.

Note: If the Network ID at the printer is all zeros, the printer will accept all Request Packets regardless of the DST. Z-ID received. If a Request Packet is received with the DST. Z-ID all zeros, it is accepted by all printers regardless of their Network ID setting.
 - * The Data Format begins with STX and ends with ETX.
 - * The Sequence Number has not been used before.

If the check is satisfactory.....

Proceed to Step 3.

If any part of the check is unsatisfactory.....

The printer discards the data in its Receive Data Buffer and waits for another SOH.

No response is sent to the computer.

Exceptions.....

It is possible that the printer will send a response to the host that the host does not receive. Therefore, the host will send the same request packet to the printer again. If this happens, the printer *will not* use the data since it already used it before. However the printer *will send* a response back to the host.

3. The printer calculates the CRC and compares it with the one received in the Request Packet. If the CRC is valid, the printer sends an Positive Response Packet to the Host computer. It then transfers the 'Variable Length' data from the Receive Buffer to its memory for processing. If the CRC does not match, and the printer is set up to return a Negative Response Packet, the following will take place.
 - a. The printer assumes that the DST. Z-ID, SRC. Z-ID, and Sequence Number are correct and that the error was in the variable data.
 - b. The same DST. Z-ID, printers SRC. Z-ID, and Sequence Number will be returned back to the host in the Negative Response Packet.
 - c. If the assumption in (a) is incorrect, the Host computer can time-out and retransmit the original Request Packet.

How the Zebra Printer Responds to Host Status

If a ~HS (Host Status) instruction is received by the Zebra printer, the printer will send back an acknowledgment for the receipt of the packet. It then sends an additional packet that includes the Host Status information in the Variable Length portion of the packet.

THIS PAGE INTENTIONALLY LEFT BLANK

Index

A

Abort Download Graphic (~DN)	6-8
ASCII Code Chart	A-1
Alphanumeric Font (^AX)	4-6
ASCII Control Characters	
For ^XA and ^XZ	2-6
AUTOEXEC.ZPL	
Definition and Usage	2-26
Axis Reference Point	
See Label Home Position	

B

Backfeed Sequence Control (~JS)	7-26
Bar Code Instructions	
ANSI Codabar (^BK)	5-16
Code 11 (^B1)	5-8
Code 128 Bar Code (^BC)	5-40
Code 39 Bar Code (^B3)	5-36
Code 49 Bar Code (^B4)	5-52
Code 93 Bar Code (^BA)	5-38
EAN-13 (^BE)	5-28
EAN-8 (^B8)	5-24
Industrial 2 of 5 (^BI)	5-12
Interleaved 2 of 5 (^B2)	5-10
Logmars Bar Code (^BL)	5-46
MSI Bar Code (^BM)	5-18
PDF417 Bar Code (^B7)	5-56
Plessey Bar Code (^BP)	5-20
POSTNET Bar Code (^BZ)	5-22
Standard 2 of 5 (^BJ)	5-14
UPC-A Bar Code (^BU)	5-34
UPC-E (^B9)	5-26
UPC/EAN Extensions (^BS)	5-30

INDEX

Bar Code Validation	
Code Validation (^CV)	5-60
Bar Codes	
Basic Format	5-1
Check Digits	5-1
Default (^BY)	5-6
Default Parameters (defined)	5-6
Defined by Groups	5-5
Field Instructions (defined)	5-2
Parameter String (defined)	5-2
Parameters (defined)	5-3
Start and Stop Characters	5-1
Supported by STRIPE Printer	5-2
Typical Instructions to Print	5-4
Beginning (Opening) Bracket (^XA)	2-6
Bit Map Font Size	
Explained	4-11
Bit Map Fonts	
Differences Between Scalable Fonts	4-13
Bit Mapped Characters	
Magnification Factor	4-2
Bit Mapped Font Magnification	
Understanding	4-2

C

Cache On (^CO)	4-14
Notes on Print Cache Performance	4-16
Cancel All (~JA)	7-20
Cancel Current Partial Format (~JX)	7-20
Caret (^) Character	
Definition and Usage	2-4
Change Alphanumeric Font (^CF)	4-5
Change Bar Code Defaults (^BY)	5-6
Change Carat (^CC or ~CC)	7-30
Change Delimiter (^CD or ~CD)	7-31
Change International Font (^CI)	4-3
Change Tilde (^CT or ~CT)	7-31

Changing Delimiter and Instruction Prefixes
 Introduction 7-30

Check Digits
 See Bar Codes

Code 49 Bar Code (^B4)
 Format and Parameters 5-53

Code Page 850 Chart F-1

Comment (^FX) 7-1

Communication Diagnostic Instructions
 Enable Communications (~JD) 7-32

Communication Diagnostics Instructions
 Introduction 7-32

Configuration Update (^JU) 3-12

Control Instructions
 Basic Format 7-17
 See Cancel All (~JA)
 See Cancel Current Partial Format (~JX)
 Definition and Usage 2-4
 See Graphing Sensor Calibration (~JG)
 See Host Status (~HS)
 Introduction 7-17
 See Media Feed (^MF)
 See Media Sensor Calibration (~JC)
 See Memory Status (~HM)
 See Pause and Cancel Format (~JP)
 See Power On Reset (~JR)
 Prefix Rules and Syntax 2-4
 See Print Quantity (^PQ)
 See Print Rate (^PR)
 See Print Start (~PS)
 See *also* Printer Control Instructions
 See Programmable Pause (^PP or ~PP)
 See Set Dots/Millimeter (^JM)
 See Set Label Length (~JL)
 See Slew Number of Dot Rows (^PF)
 See Slew to Home Position (^PH or ~PH)
 See Suppress Backfeed (^XB)

INDEX

D

Database Programs	
Used to Create ZPL II Programs	2-2
Define Language (^KL)	7-29
Define Password (^KP)	7-29
Device Names	
Introduction to	2-24
Using with ZPL II Instructions	2-25
Disable Diagnostics (~JE)	7-32
Download Bitmap Font (~DB)	4-17
Download Format (^DF)	7-11
Download Graphic (~DG)	6-4
Download Scalable Font (~DS)	4-20
Downloadable Scalable Fonts	
Introduction	4-19

E

Enable Communications Diagnostics (~JD)	7-32
Ending (Closing) Bracket (^XZ)	2-6
Erase Downloaded Graphic (^EG or ~EG)	6-18
Erase Format (^EF or ~EF)	7-10
Error Detection Protocol	G-1
Examples	
Bit Map Font Size	4-11
Code 11 Bar Code (^B1)	5-8
Code 128 Bar Code (^BC)	5-40
Code 128 Bar Code - Subset A	5-45
Code 128 Bar Code - Subset B	5-44
Code 128 Bar Code - Subset C	5-45
Code 39 Bar Code (^B3)	5-36
Code 49 Bar Code (^B4)	5-52
Code 93 Bar Code (^BA)	5-38
Code Validation (^CV)	5-61
Drawing a Box	6-3
Drawing a Horizontal Line	6-3
Drawing a Vertical Line	6-3
EAN-13 Bar Code (^BE)	5-28
EAN-8 Bar Code (^B8)	5-24
Industrial 2 of 5 Bar Code (^BI)	5-12

INDEX

Interleaved 2 of 5 Bar Code (^B2)	5-10
Logmars Bar Code (^BL)	5-46
Media Used	1-2
MSI Bar Code (^BM)	5-18
Parameters Used	1-3
PDF417 Bar Code (^B7)	5-56
Plessey Bar Code (^BP)	5-20
POSTNET Bar Code (^BZ)	5-22
Standard 2 of 5 Bar Code (^BJ)	5-14
Standard 2 of 5 Bar Code (^BK)	5-16
Transfer Object (^TO)	6-16
Using ^WD (Print Directory)	7-15
UPC-A Bar Code (^BU)	5-34
UPC-E Bar Code (^B9)	5-26
UPC/EAN Extensions	5-30
Using ^AØ (Scalable Alphanumeric Font)	4-12
Using ^AX (Alphanumeric Font)	4-7
Using ^CO (Cache On)	4-15
Using ^CW (Font Identifier)	4-22
Using ^DF (Download Format)	7-12
Using ^FH (Field HEX)	2-20
Using ^FO, ^FD, and ^FS (Fields)	2-19
Using ^FR (Field Reverse Print)	7-2
Using ^FV (Field Variable Data)	7-9
Using ^FX (Comment)	7-1
Using ^GS (Graphic Symbol)	4-4
Using ^HW (Host Status List)	7-34
Using ^ID (Image Delete)	6-17
Using ^IL (Image Load)	6-14
Using ^IM (Image Move)	6-11
Using ^IS to Save a Label Format	6-13
Using ^LR (Label Reverse Print)	7-3
Using ^MD (Media Darkness)	3-6
Using ^MP (Mode Protection)	3-10
Using ^PM (Print Mirror Image)	7-4
Using ^PQ (Print Quantity)	7-23
Using ^SN (Serialized Data)	7-7
Using ^XA and ^XZ (Format Brackets)	2-6
Using ^XF (Recall Format)	7-14
Using ^XG (Recall Graphic)	6-10
Using ~DB (Download Bit Map)	4-18

INDEX

Using ~DG (Download Graphic)	6-5
Using ~DS (Download Scalable Font).....	4-20
Examples (Working With)	1-2

F

Factory Defaults	
How to Set for Examples	1-3
Field Allocate (^FA)	7-13
Field Block (^FB)	2-21
Field Data (^FD).....	2-18
Field Data Instruction	
Maximum Characters Allowed.....	2-18
Field Definition Instructions	
^FO, ^FT, ^FD and ^FS	2-15
Field HEX (^FH).....	2-20
Field Number (^FN)	7-13
Field Orientation (^FW)	2-12
Field Origin (^FO)	2-15
See also Understanding ^FO and ^FT	
Field Reverse Print (^FR)	7-2
Field Separator (^FS).....	2-19
Field Typset (^FT)	2-16
See also Understanding ^FO and ^FT	
Field Variable Data (^FV).....	7-9
Font Identifier (^CW)	4-21
Fonts	
Selecting	4-5
Format Bracket Instructions	
^XA and ^XZ	2-6
Format Instructions	
Definition and Usage.....	2-3
Format Brackets (^XA & ^XZ)	2-6
Format Rotation.....	2-12
Prefix Rules and Syntax	2-4
Format Rotation Instructions	
^FW and ^PO	2-12

G

Graphic Box (^GB).....	6-2
Graphic Images	
Deleting from Memory	6-17
Determining Size in Bytes	6-5
Hexadecimal Format Requirement	2-1
Reducing Download Time	6-9
Saving in HEX Format	6-4
Saving Label Formats as Graphics	6-12
Sources Of	6-1
Types Available	6-1
Use of Hexadecimal Format	6-1
Graphic Instructions	
Abort Download Graphic (~DN).....	6-8
Download Graphic (~DG)	6-4
Erase Downloaded Graphic (^EG or ~EG)	6-18
Graphic Boxes (^GB).....	6-2
Image Delete (^ID)	6-17
Image Load (^IL)	6-14
Image Move (^IM)	6-11
Image Save (^IS).....	6-12
Recall Graphic (^XG).....	6-10
Transfer Objects (^TO)	6-15
Graphic Symbol (^GS).....	4-4
Graphing Sensor Calibration (~JG).....	7-19

H

Head Test Fatal (~JN)	7-18
Head Test Interval (^JT).....	7-18
Head Test Non-Fatal (~JO)	7-18
HEX Codes	
Embedding in ^FD Statements	2-20
HEX Images	
See Graphic Images	
Host Directory List (^HW)	7-33
Host Identifier (~HI)	7-35

INDEX

Host Status (~HS)	7-17
Host Status Return Strings	
Defined	D-1
Host Verification (^HV)	7-35

I

Image Delete (^ID)	6-17
Image Load (^IL)	6-14
Image Move (^IM)	6-11
Image Save (^IS)	6-12
Format and Parameters	6-12
International Character Sets	
Supported	4-3
ISBN (International Standard Book Number)	
See UPC/EAN Extensions	

J

JAN-13 Bar Code	
See EAN-13 Bar Code	
JAN-8 Bar Code	
See EAN-8 Bar Code	

L

Label Definition Instructions	
^LH, ^LL, ^LS	2-7
Label Format Instructions	2-6
Label Home (^LH)	2-7
Label Home (^LH)	2-7
Label Home Position	
Defined	2-7
Label Length (^LL)	2-9
Label Reverse Print (^LR)	7-3
Label Shift (^LS)	2-10
Label Top (^LT)	3-7

M

Map Clear (^MC) 7-8
 Media Darkness (^MD) 3-6
 Media Feed (^MF) 7-19
 Media Sensor Calibration (~JC)..... 7-19
 Media Tracking (^MN) 3-4
 Media Type (^MT) 3-5
 Memory Status (~HM) 7-17
 Memory Status Return
 Defined E-1
 Mod 43 Check Digit
 Calculating..... C-1
 Mode 10 Check Digit
 Calculating..... B-1
 Mode Protection (^MP) 3-10
 Multiple Label Formats
 How Handled..... 2-3

N

Network
 Using Printers In 7-41
 Network Connect (~NC)..... 7-39
 Network ID Number (^NI)..... 7-38
 Networking
 How to Set Up..... 7-40
 Nonprinting Comments
 Comment (^FX)..... 7-1

O

Object Names and Extensions
 Introduction to 2-24
 Using with ZPL II Instructions 2-25

INDEX

P

Pause and Cancel Format (~JP)	7-20
Power On Reset (~JR)	7-17
Preprinted Labels	
Printing on	5-1
Print Configuration Label (~WC)	7-36
Print Directory (^WD)	7-15
Print Mirror Image (^PM)	7-4
Print Mode (^MM)	3-3
Print Orientation (^PO)	2-14
Print Quantity (^PQ)	7-23
Explanation of 'o' Parameter	7-23
Print Rate (^PR)	7-24
Limitations of Higher Print Speeds	7-25
Print Start (~PS)	7-21
Printer Configuration	
List of Instructions	3-1
Saving	3-2
Setting Up Customized Formats	3-14
Printer Control Instructions	
Change Backfeed Sequence (~JS)	7-26
Programmable Pause (^PP or ~PP)	7-21
Proportional Spacing	
Defined	4-10

Q

Quiet Zone	
Defined	5-1

R

Recall Format (^XF)	7-14
Recall Graphic (^XG)	6-10
Reprint After Error (^JZ)	3-11
Reset Battery Dead (~JB)	2-26

S

Scalable Font (^AØ)..... 4-12

Scalable Fonts

Differences Between Bit Map Fonts 4-13

Serialized Data

Introduction 7-5

Serialized Data (^SN) 7-6

Set ALL Network Printers Transparent (~NR) 7-39

Set Dots/Millimeter (^JM)..... 7-28

Set Label Length (~JL) 7-19

Set Media Sensor (^SS) 3-8

Set Media Sensor Calibration (~JL)..... 7-17

Set Network Printer Transparent (~NT)..... 7-39

Set ZPL (^SZ) 3-13

Slew Number of Dot Rows (^PF)..... 7-22

Slew to Home Position (^PH or ~PH) 7-21

Special Effects

See Field Reverse Print (^FR)

See Label Reverse Print (^LR)

See Print Mirror Image (^PM)

Start Character

See Bar Codes

Start Print (^SP)..... 7-36

Stop Character

See Bar Codes

Stored Format Instructions

Download Format (^DF) 7-11

Stored Formats

See Download Format (^DF)

See Erase Format (^EF or ~EF)

See Field Allocate (^FA)

See Field Number (^FN)

Introduction 7-10

See Recall Format (^XF)

Suppress Backfeed (^XB) 7-27

INDEX

T

Test/Setup Control Instructions	
Head Test Fatal (~JN)	7-18
Head Test Interval (^JT)	7-18
Head Test Non-Fatal (~JO)	7-18
Tilde (~) Character	
Definition and Usage	2-4
Transfer Objects (^TO)	6-15

U

Understanding ^FO and ^FT	2-17
USD-3 Bar Code	
See Code 39 Bar Code	
USD-8 Bar Code	
See Code 11 Bar Code	

V

Variable Data	
See Field Variable Data (^FV)	
Introduction	7-8
See Map Clear (^MC)	
Variable Data Instructions	
Field Variable Data (^FV)	7-9

W

Word Processors	
Used to Create ZPL II Programs	2-2

Z

ZPL II	
Features and Compatibility	2-1
How It Differs from Standard ZPL	1-1
Instructions (defined).	2-1

Programming Language (defined).....	1-1
ZPL II Instructions	
^AØ (Scalable Font)	4-12
^AX (Alphanumeric Font)	4-6
^B1 (Code 11)	5-8
^B2 (Interleaved 2 of 5)	5-10
^B3 (Code 39)	5-36
^B4 (Code 49)	5-52
^B7 (PDF417)	5-56
^B8 (EAN-8)	5-24
^B9 (UPC-E)	5-26
^BA (Code 93)	5-38
^BC (Code 128)	5-40
^BE (EAN-13)	5-28
^BI (Industrial 2 of 5)	5-12
^BJ (Standard 2 of 5)	5-14
^BK (ANSI Codabar)	5-16
^BL (LOGMARS)	5-46
^BM (MSI)	5-18
^BP (Plessey)	5-20
^BS (UPC/EAN Extensions)	5-30
^BU (UPC-A)	5-34
^BY (Change Narrow Bar Width)	5-6
^BZ (POSTNET)	5-22
^CC, ~CC (Change Carat)	7-30
^CD, ~CD (Change Delimiter)	7-31
^CF (Change Alphanumeric Default Font)	4-5
^CI (Change International Font)	4-3
^CO (Cache On)	4-14
^CT, ~CT (Change Tilde)	7-31
^CV (Code Validation)	5-60
^CW (Font Identifier)	4-21
~DB (Download Bitmap Font)	4-17
^DF (Download Format)	7-11
^DG (Download Graphic)	6-4
^DN (Abort Download Graphic)	6-8
~DS (Download Scalable Font)	4-20
^EF, ~EF (Erase Format)	7-10
^EG, ~EG (Erase Downloaded Graphics)	6-18
^FA (Field Allocate)	7-13
^FB (Field Block)	2-21

INDEX

^FD (Field Data)	2-18
^FH (Field Hex)	2-20
^FN (Field Number)	7-13
^FO (Field Orientation)	2-15
^FR (Field Reverse Print)	7-2
^FS (Field Separator)	2-19
^FT (Field Typeset)	2-16
^FV (Variable Field Data)	7-9
^FW (Field Orientation)	2-12
^FX (Comment)	7-1
^GB (Graphic Box)	6-2
^GS (Graphic Symbol)	4-4
~HI (Host Identification)	7-35
~HM (Memory Status)	7-17
~HS (Host Status)	7-17
^HV (Host Verification)	7-35
^HW (Host Directory List)	7-33
^ID (Image Delete)	6-17
^IL (Image Load)	6-14
^IM (Image Move)	6-11
^IS (Image Save)	6-12
~JA (Cancel All)	7-20
~JB (Reset Battery Dead)	2-26
~JC (Set Media Sensor Calibration)	7-19
~JD (Enable Communications Diagnostics)	7-32
~JE (Disable Diagnostics)	7-32
~JG (Graphing Sensor Calibration)	7-19
~JL (Set Label Length)	7-19
^JM (Set Dots per Millimeter)	7-28
~JN (Head Test Fatal)	7-18
~JO (Head Test Non-Fatal)	7-18
~JP (Pause and Cancel Format)	7-20
~JR (Power On Reset)	7-17
~JS (Change Backfeed Sequence)	7-26
^JT (Head Test Interval)	7-18
^JU (Configuration Update)	3-12
~JX (Cancel Current Partially Input Format)	7-20
^JZ (Reprint After Error)	3-11
^KL (Define Language)	7-29
^KP (Define Password)	7-29
^LH (Label Home)	2-7

INDEX

^LL (Label Length)	2-9
^LR (Label Reverse Print)	7-3
^LS (Label Shift)	2-10
^LT (Label Top)	3-7
^MC (Map Clear)	7-8
^MD (Media Darkness)	3-6
^MF (Media Feed)	7-19
^MM (Print Mode)	3-3
^MN (Media Tracking)	3-4
^MP (Mode Protection)	3-10
^MT (Media Type)	3-5
~NC (Network Connect)	7-39
^NI (Network ID Number)	7-38
~NR (Set all Network Printers Transparent)	7-39
~NT (Set Network Printer Transparent)	7-39
^PF (Slew Given Number of Dot Rows)	7-22
^PH, ~PH (Slew to Home Position)	7-21
^PM (Print Mirror Image)	7-4
^PO (Print Orientation)	2-14
^PP, ~PP (Programmable Pause)	7-21
^PQ (Print Quantity)	7-23
^PR (Print Rate)	7-24
~PS (Print Start)	7-21
^SN (Serialized Data)	7-6
^SP (Start Print)	7-36
^SS (Set Media Sensor)	3-8
^SZ (Set ZPL)	3-13
^TO (Transfer Object)	6-15
~WC (Print Configuration Label)	7-36
^WD (Print Directory on Label)	7-15
^XA (Start Format)	2-6
^XB (Suppress Backfeed)	7-27
^XF (Recall Format)	7-14
^XG (Recall Graphic)	6-10
^XZ (End Format)	2-6

